



HALFEN

Leviat[®]
A CRH COMPANY

Halfen HIT Insulated Connection Steel to Concrete Connector

Technical Product Information

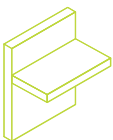

Structural Connections
Insulated balcony connections

English

Imagine. Model. Make.

Leviat®

A CRH COMPANY

We imagine, model and make engineered products and innovative construction solutions that help turn architectural visions into reality and enable our construction partners to build better, safer, stronger and faster.

Leviat is a world leader in connecting, fixing, lifting and anchoring technology.

From the build of new schools, hospitals, homes and infrastructure, to the repair and maintenance of heritage structures, our engineering skills are making a difference around the world.

We provide technical design assistance at every stage of a project, from initial planning to installation and beyond.

Our technical support services range from simple product selection through to the development of a fully customised project-specific design solution.

Every promise we make locally, has the commitment and dedication of our global team behind it. We employ almost 3,000 people at 60 locations across North America, Europe and Asia-Pacific, providing an agile and responsive service worldwide.

Leviat, a CRH company, is part of the world's leading building materials business.



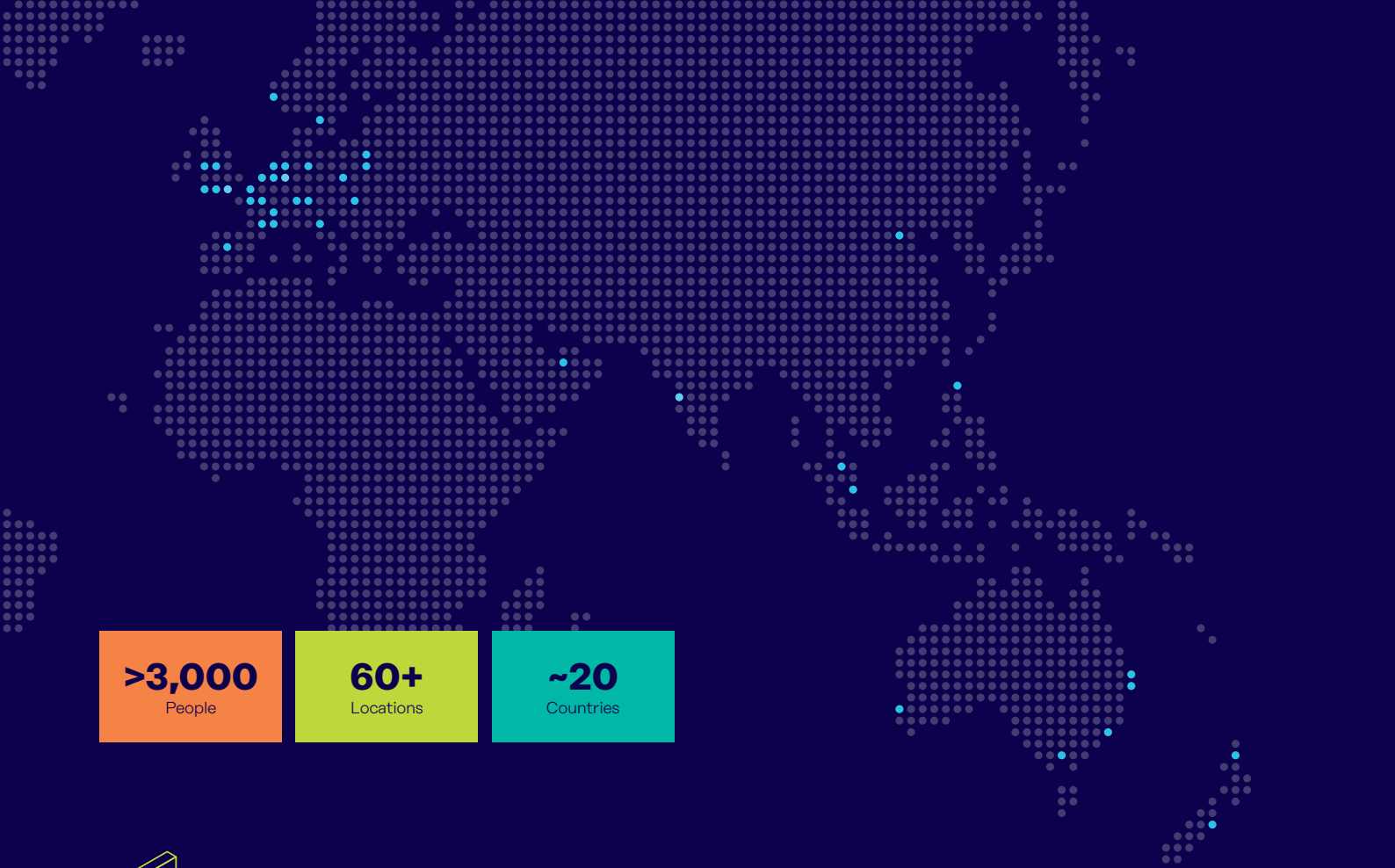

>3,000
People

60+
Locations

~20
Countries

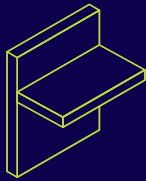

Structural Connections

Systems to form robust, efficient connections, and continuity of concrete reinforcement as necessary, between walls, slabs, columns, beams and balconies, providing structural integrity as well as enhanced thermal and acoustic performance.

- Insulated balcony connectors
- Reinforcing bar couplers
- Concrete Connections
- Reinforcement continuity systems
- Punching shear reinforcement
- Shear load connectors
- Floor Joint Systems
- Precast / Reinforced Columns
- Infrastructure Products
- Precast Connections
- Acoustic dowels and bearings
- Prestress

Other areas of expertise:

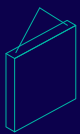

Lifting & Bracing

Systems for the safe and efficient transportation, lifting and temporary bracing of cast concrete elements and tilt-up panels before permanent structural connections are made.

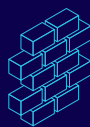

Façade Support & Restraint

Systems for the safe and thermally-efficient fixing of the external building envelope, including brick and natural stone, insulated sandwich panels, curtain walling and suspended concrete façades, and also the repair and strengthening of existing masonry installations.

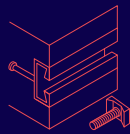

Anchoring & Fixing

Systems for fixing secondary fixtures to concrete, including anchor channels, bolts and inserts; also tension rod systems for roofs and canopies.



Formwork & Site Accessories

Non-structural accessories that complement our engineered solutions and help keep your construction environment operating safely and efficiently, including moulds for casting standard and special concrete elements and construction essentials such as reinforcing bar spacers.

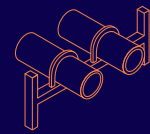

Industrial Technology

Mounting channels, pipe clamps and other versatile framing systems that provide safe fixing in a wide range of industrial applications.

Leviat product ranges:

Ancon | Aschwanden | Connolly | Halfen | Helifix | Isedio | Meadow Burke | Modersohn | Moment | Plaka | Scaldex | Thermomass



Halfen HIT Steel to Concrete Connector

Contents

Halfen HIT Insulated connection – Steel to concrete connection	6	
Overview of benefits	7	
Building materials/Test certificates	9	
Notes on calculation	10	
Verifying correct installation	13	
Using the installation aid	14	
1 HIT-HP SDV / HIT-SP SDV	16	New types available!
Load capacity range	17	
Load capacity values	18	
Product specifications	34	
On-site reinforcement	36	
Deformation	38	
Torsion spring stiffnesses	39	
Axial spacing, edge distance	40	
Installation instructions	42	
2 HIT-HP SMV / HIT-SP SMV	44	New types available!
Load capacity range	45	
Load capacity values	46	
Product specifications	52	
On-site reinforcement	53	
Deformation	54	
Torsion spring stiffnesses	55	
Axial spacing, edge distance	56	
Installation instructions	58	
3 HIT-HP SZV / HIT-SP SZV	60	New types available!
Load capacity range	61	
Load capacity values	62	
Product specifications	63	
On-site reinforcement	64	
Axial spacing, edge distance	65	
Installation instructions	67	
4 Construction and installation of connecting components	69	
On-site facing plate with notch	70	
Connecting supports	72	
Installation and height adjustment	73	
Installation, structural steel	74	
Expansion joint spacings	75	
5 Building physics	76	
Characteristic values for thermal bridges	77	
Characteristic thermal values according to Building Authority Approval	78	
Characteristic thermal values for HIT-HP Insulated connections	88	
Characteristic thermal values for HIT-SP Insulated connections	91	
Addresses / Technical support	94	

Halfen HIT Steel to Concrete Connector

Introduction

Halfen HIT Steel to Concrete Connector

Steel balconies, canopies, and solar shading systems are typically connected to reinforced concrete components. Due to the high thermal conductivity of steel, effective thermal separation at these connection points is essential. Without it, thermal bridges can occur, leading to increased energy consumption and potential structural damage from condensation and mould.

The Halfen HIT Steel-to-Concrete Connectors provide an optimal solution by minimising thermal bridges while ensuring exceptional high load-bearing performance.

With the update of type testing, the product portfolio now includes the following load-bearing levels:

- Elements with 2M12 for HIT-SDV/SMV/SZV – the smallest load-bearing option, ideal for lightweight canopies.
- Elements with 2M20 for HIT-SDV – designed for steel balconies.

At the core of each element is a statically effective system of compression, tension, and shear bars, securely anchored on-site into load-bearing concrete components.

On the balcony (exterior) side, the system incorporates tension and compression rods with metric connection threads for reliable load transfer. An angled slotted bracket allows flexible height adjustment of connected components.

The load-bearing elements are fully enclosed in non-combustible mineral wool insulation, ensuring outstanding thermal separation. A durable housing encases the insulation, providing protection against mechanical damage and weather exposure.

All load-bearing components, both within the connection and on the exterior balcony side, are manufactured from stainless steel. This ensures long-term corrosion protection and maximum durability.

The following types of insulated connection are available:

HIT-SDV For freely cantilevered steel elements, designed to transfer positive and negative bending moments, positive and negative shear forces, as well as forces parallel to the joint in both directions.

HIT-SMV For freely cantilevered steel elements, designed to transfer negative bending moments, positive and negative shear forces, as well as forces parallel to the joint in both directions.

HIT-SZV For simply supported elements connected to reinforced concrete slabs, designed to transfer positive and negative shear forces, as well as forces parallel to the joint in both directions.

- All types are available with 80 mm (HIT-HP) and 120 mm (HIT-SP) insulation thickness.

Thanks to their intelligent bar arrangement, the HIT-SMV and HIT-SZV are particularly well-suited for use with semi-precast filigree slabs. Their short anchor heads prevent interference with the slab reinforcement.

For ease of handling, all connection types are delivered with a pre-fitted installation aid, allowing precise adjustment and simplifying installation within the formwork.

HIT-HP SMV-2M16

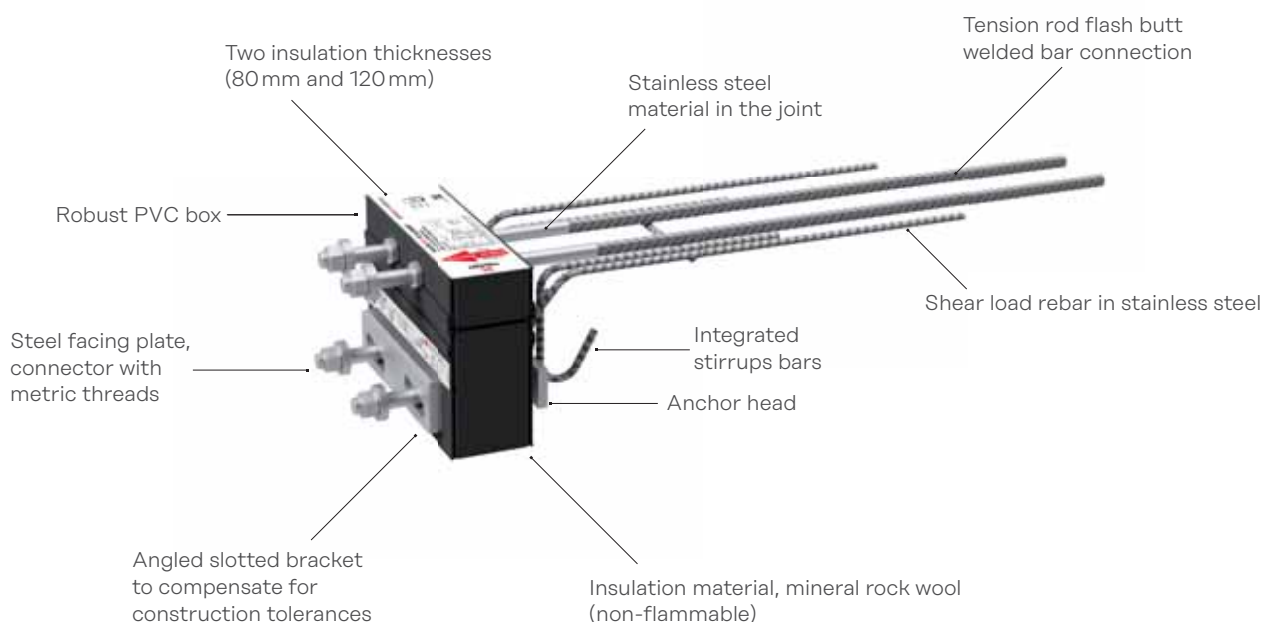

Halfen HIT Steel to Concrete Connector

Product Overview – Thermally Insulated Connections

The benefits at a glance

Reliable design and planning

- Building Authority Approval including determination of the equivalent thermal conductivity (λ_{eq})
- Type-tested for assured performance
- Chi-values for masonry with *ETICS available (other values on request)

*ETICS External Thermal Insulation Composite System.



Robust housing

- Strong and durable box construction, ideal for on-site conditions
- Weather-resistant for dependable insulation protection
- Ensures a secure connection of attached steel components

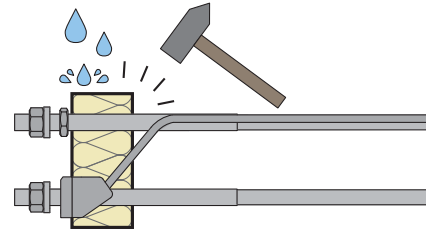

Pre-fitted installation aid

- Installation aid is pre-fitted as standard
- Simplifies positioning and adjustment within the formwork
- All necessary components included – so no extra costs

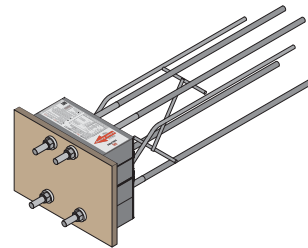

Vertical adjustment of the steel with an angled slotted bracket

- Pre-fitted steel bracket with angled slots enables vertical adjustment through lateral movement
- Freely adjustable for precise alignment
- Sturdy design suitable for demanding construction environments

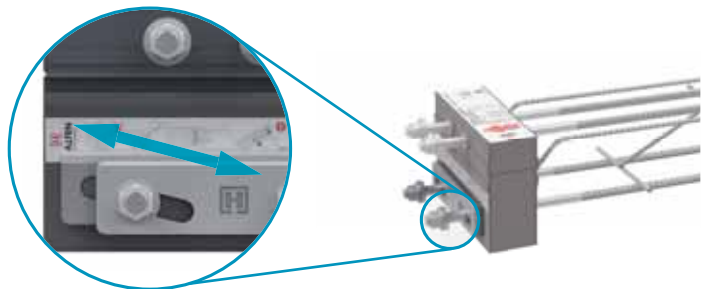

Reliable notched support

- Angled slotted bracket with bevelled edge ensures a flat support surface for the connecting notch
- Prevents unintentional movement or twisting
- Guarantees secure, force-locked load transfer

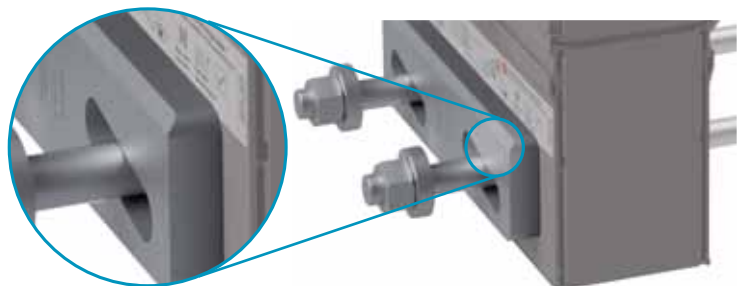

Halfen HIT Steel to Concrete Connector

Product Overview – Thermally Insulated Connections

SDV

1

1 Cantilevered balcony slabs

HIT-HP SDV / HIT-SP SDV

Transfer of bi-directional bending moments and shear forces, as well as bidirectional forces parallel to the joint

insulation thickness 80 mm / 120 mm

→ Page 16

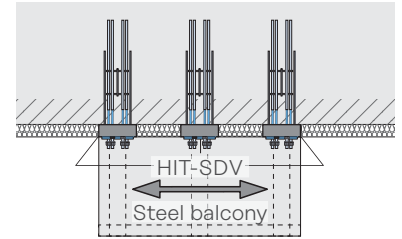
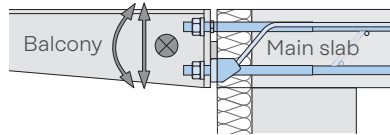

SMV

2

2 Cantilevered balcony slabs

HIT-HP SMV / HIT-SP SMV

Transfer of negative bending moments and positive shear loads and bidirectional forces parallel to the joint

insulation thickness 80 mm / 120 mm

→ Page 44

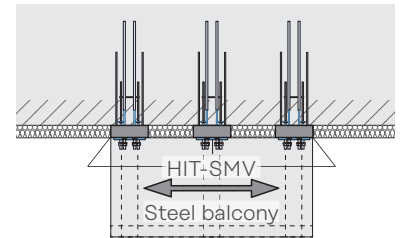
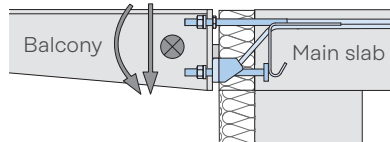

SZV

3

3 Simply supported balcony slabs on columns

HIT-HP SZV / HIT-SP SZV

Transfer of positive shear forces and bidirectional forces parallel to the joint

insulation thickness 80 mm / 120 mm

→ Page 60

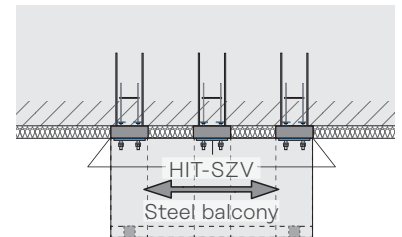
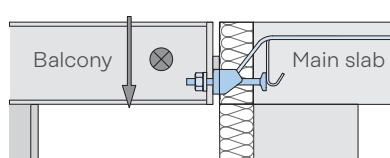

CONSTRUCTION

4

4 Construction

HIT-HP/SP SDV, SMV, SZV

Design and installation of connected components

→ Page 69

BUILDING PHYSICS

5

5 Building physics parameters

HIT-HP/SP SDV, SMV, SZV

Building physics

→ Page 76

Halfen HIT Steel to Concrete Connector

Material Specification and Test Certificates

Materials; HIT Elements

Tension/compression bars	Flash butt welded bar connection, consisting of a combination of two reinforcing steel bars B500 according to DIN 488, and stainless steel bars of strength class S690 or stainless steel B500NR with partial or full metric threads, for connection of steel components to the (exterior) side of the HIT element.
Load-bearing support	Stainless steel bars, strength class S690 with partial or full metric threads on the steel connection side of the element, and anchor heads on the concrete side.
Shear load rebar	Stainless steel bars in strength class B500NR or flash butt welded bar connection, consisting of a combination of stainless steel bar B500NR and reinforcing steel bars B500
Installation bracket	Stainless steel, strength class S460
Angled slotted bracket	Stainless steel, strength class S235
Accessories	Stainless steel washers in strength class S460, Stainless steel bolt-nuts in strength class A4-80
Box	PVC plastic according to EN ISO 1163
Insulation material	Mineral wool (WLG 035) Building Material Class A1 – non-flammable insulation according to DIN 4102-14 or Euroclass A1 in accordance with EN 13501-1

1 SDV

2 SMV

3 SZV

Materials; load-bearing concrete components

Concrete	Suitable for concrete strength \geq C20/25
On-site reinforcement	B500 Reinforcement steel

Materials; connected steel components

Steel	Steel according to EN 1993 or stainless steel according to approval Z-30.3-6 Required minimum strength class of steel on the balcony side: S 235
-------	---

4 CONSTRUCTION

Test certificates

Building Authority Approvals	
HIT-HP/SP SDV HIT-HP/SP SMV HIT-HP/SP SZV	DIBT* Berlin: Approval no Z-15.7-336 *(German Institute of Building Technology)
Type tests	
Type tested by the LGA Landesgewerbeanstalt Bayern	Test no. S-WUE/220348 (German certification institute)

5 BUILDING PHYSICS

Approvals and type tests on the internet

The approvals and type tests can be found at www.halfen.com/downloads/brochures.



Halfen HIT Steel to Concrete Connector

Calculation

Notes on calculation

This connection system provides a thermally insulated, load-bearing interface between steel components and reinforced concrete structures.

The reinforced concrete element must comply with EN 1992-1-1, with a minimum concrete strength of C20/25 and a density range of 2,000–2,600 kg/m³. The connected steel components (e.g., balconies, canopies) must be designed in accordance with EN 1993. The system is intended for predominantly static loads.

Both the load-bearing concrete and the connected steel elements must be verified by a qualified structural engineer in line with current standards:

- EN 1992-1-1 for the concrete component
- EN 1993 for the steel component
- EN 1991 for the calculation of applied loads

Where indirect support of the HIT element is required, the transfer of forces from the connected element to the supporting structure must also be separately verified by the structural engineer.

The insulation element is not designed for torsional load transfer. A torsion-free installation must therefore be ensured, and torsional interaction between adjacent insulation elements must be prevented.

Load-bearing capacities are specified for the standard element height. For slab thicknesses exceeding the standard concrete cover, verification of the load capacities must consider the resulting internal cantilever conditions.

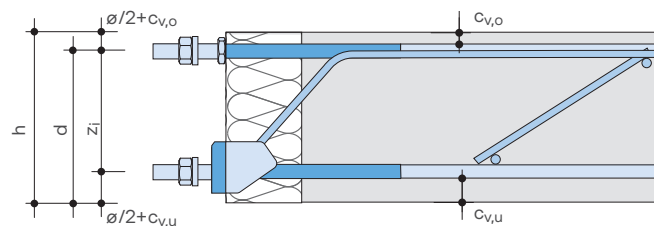

Inner cantilever and component height

Halfen HIT-HP Halfen HIT-SP	SDV 2M12 SDV 2M16 SMV 2M12 SMV 2M16	SDV 2M20 SDV 2M22
HIT Height h [mm]	Inner cantilever z_i [mm]	Inner cantilever z_i [mm]
180	113	108
200	133	128
220	153	148
240	173	168
260	193	188
280	213	208



Corrosion protection

The stainless steels used meet the requirements of corrosion resistance class III (medium). When Halfen HIT steel-to-concrete connectors are used together with galvanized or coated facing plates (e.g., painted surfaces), any galvanic corrosion is non-critical. This is due to the significantly larger surface area of the facing plates compared to the stainless steel components. As a result, contact corrosion failure of the connection is prevented.

Shortening the threaded connections

The threaded connection bars may be shortened as required; at least two threads must remain visible after final installation of steel components.

Halfen HIT Steel to Concrete Connector

Calculation

Connection details HIT-SDV / HIT-SMV

The elements are delivered with a standard width of $b = 250$ mm. Smaller widths, from $220 \leq b \leq 250$ mm are available as custom lengths on request.

The structural engineer has to verify that the design values of the loads in the selected section do not exceed the specified resistance.

The horizontal and vertical axial spacings of the tension and compression elements are decisive for the design of the connected component. The axial spacing of the tension bars is 70 mm for M16 and M22 threads and 100 mm for M12 and M20 threads, for the compression bars 115 mm.

$$M12, M16: z_i = h - 67$$

$$M20, M22: z_i = h - 72$$

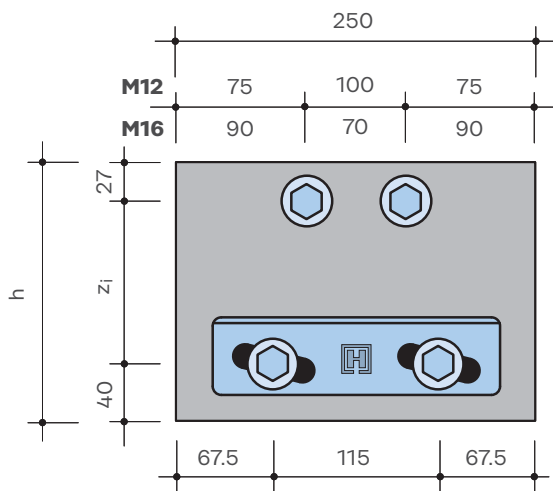

Spacings with HIT-SDV and HIT-SMV with M12/M16 thread

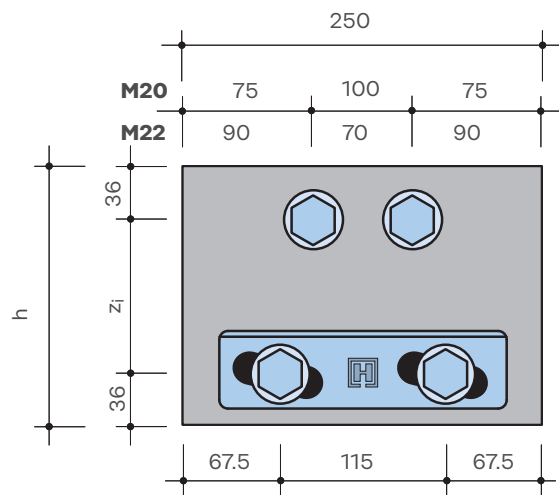

Dimensions in [mm]

Spacings with HIT-SDV with M20/M22 thread

For HIT-SDV and HIT-SMV elements, the ultimate load resistance values are provided for two reference sections. Verification may be carried out in either Section A-A or Section B-B. Since both sections are mathematically linked, a check performed in one section (typically Section B-B) automatically ensures compliance in the other.

The vertical spacing results from the selected element height h :

Section A-A Design section according to Z-15.7-336 (section in axis of tension and shear load bars)

Section B-B Design section at connection surface of steel component (surface of the facing plate to the connected component)

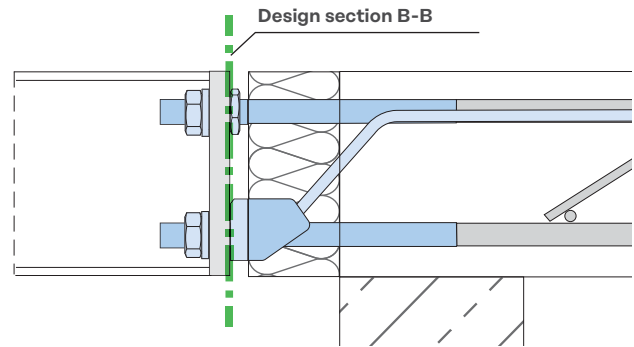
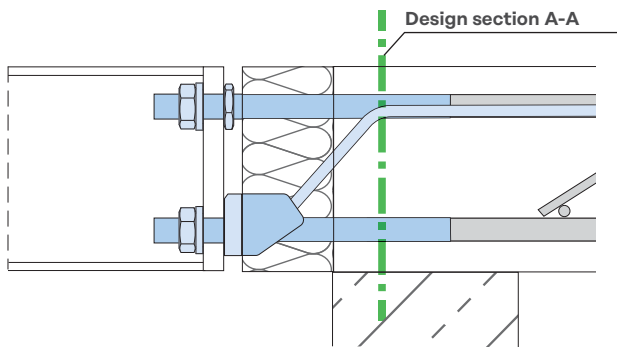

Ⓢ To be on the safe side, the design section A-A is assumed to be at a distance of approx. 80 mm.

~80 mm[Ⓢ]

Halfen HIT Steel to Concrete Connector

Calculation

SDV 1

Calculation

With HIT-SDV and HIT-SMV elements there is a dependency between the moment load capacity and the shear load in section B-B. Therefore the tables show four pairs of value V_{Rd}/M_{Rd} .

- Intermediate values may be linearly interpolated.
- Extrapolation for larger shear load values ($V_{Ed} > V_{Rd,4}$) is not possible.

SMV 2

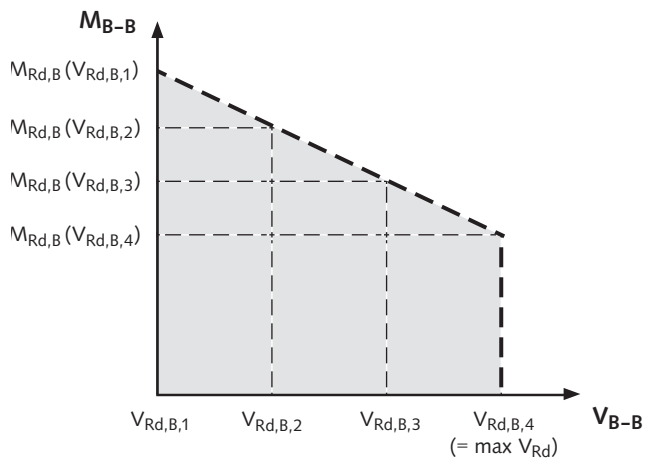

Figure: Dependency of moments and shear forces in section B-B

SZV 3

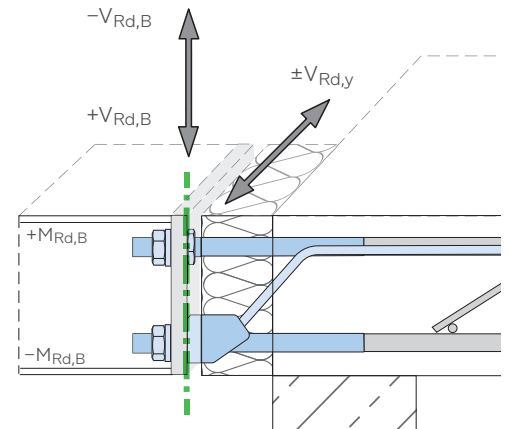

Figure: Sign convention for calculation

CONSTRUCTION 4

HIT-SZV Connection details

The HIT-SZV element is supplied with a standard width of $b = 250$ mm. Custom widths from $220 \text{ mm} \leq b \leq 250 \text{ mm}$ are available upon request. Crucial to the design of the connection element is primarily determined by the horizontal spacing of the 2 compression components and their vertical position. The axial spacing of the compression bars is 115 mm for all HIT-SZV elements.

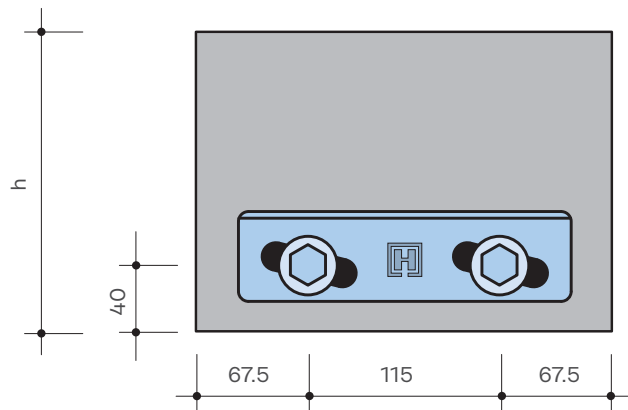
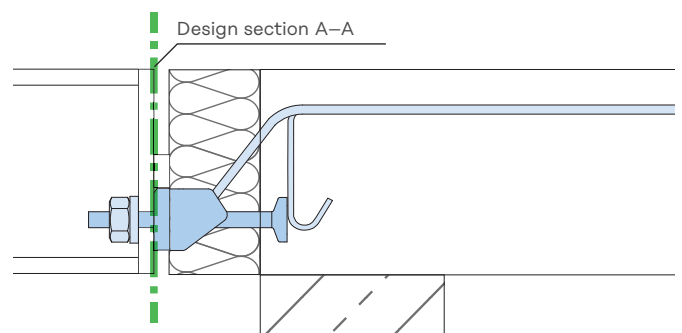

Figure: Spacings for HIT-SZV with M12- and M16-thread

BUILDING PHYSICS 5

The provided design values for load carrying capacity apply for the rear-most surface of the facing plate of the connected element. See section A-A.



Halfen HIT Steel to Concrete Connector

Verifying correct installation

Verifying correct installation

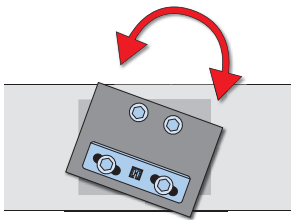

✘ incorrect: rotated horizontal orientation
Incorrect: Horizontal alignment tilted

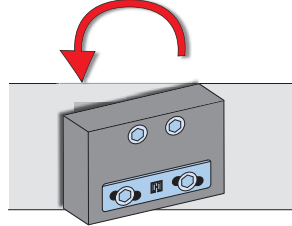

✘ incorrect: twisted horizontal orientation
Incorrect: Horizontal alignment rotated

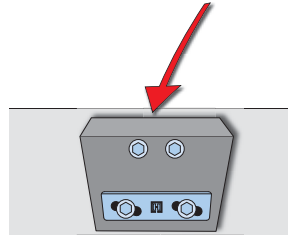

✘ incorrect: tilted vertically!
Incorrect: Vertical alignment tilted

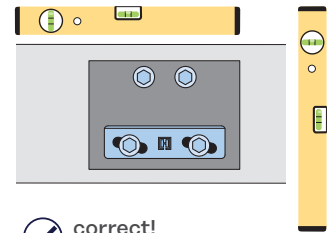

✔ correct!

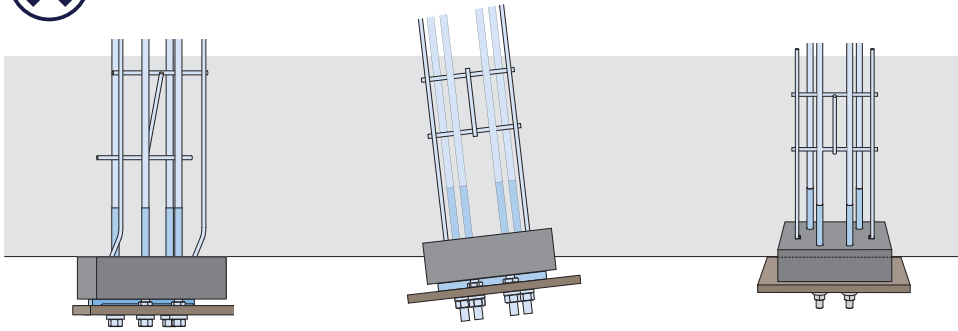

✘ incorrect: elements askew, horizontal to the concrete edge, tilted towards the front or back

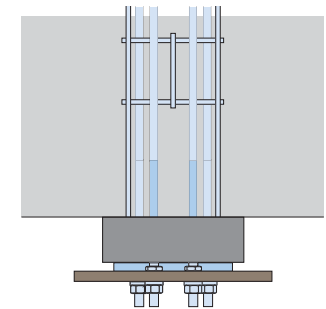

✔ correct: element aligned along axis

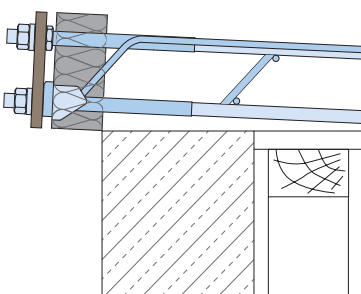

✘ incorrect: tilted vertically

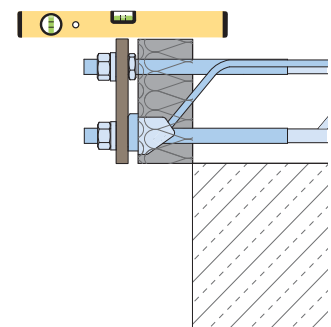
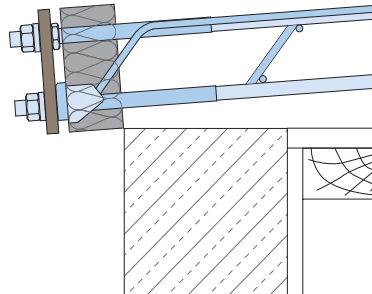

✔ correct: vertically aligned

1 SDV

2 SMV

3 SZV

4 CONSTRUCTION

5 BUILDING PHYSICS

Halfen HIT Steel to Concrete Connector

Installation aid

SDV 1

Using the installation aid

Transport protection doubles as installation aid

Each HIT steel-to-concrete connection element is delivered with transport protection that also serves as an installation aid.

The primary function of the protection board is to shield the insulation box and the connection bolts from damage while maintaining the correct bolt orientation – an essential requirement during concreting.

The protection boards should remain in place during concreting, or alternatively, corresponding holes must be provided in the on-site formwork. If left attached, the installation aids can also be used for vertical alignment and for securing the element to the formwork.

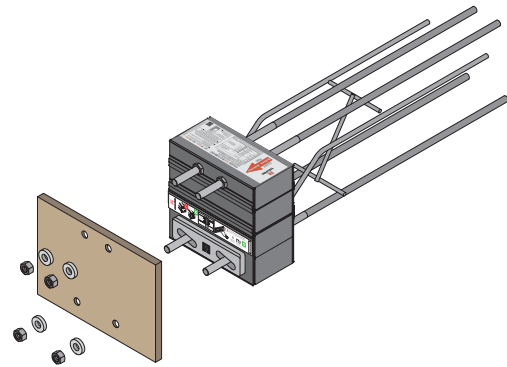

Figure: HIT-HP SDV and installation aid

The extended ends of the installation aids may be used as fixing points where required. If the elements are to be installed directly through the formwork, the aids can be removed and reused as templates for drilling holes and setting element spacing.

SMV 2

SDV 3

CONSTRUCTION 4

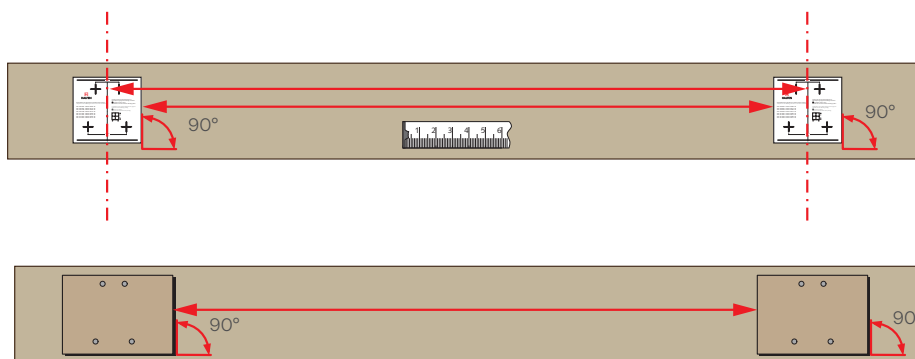

Figures: above: Installation aid on formwork using drill templates, below: Installation aid on formwork – aligned

BUILDING PHYSICS 5

Vertical orientation of the installation aid

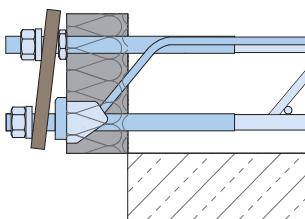

✘ incorrect: Installation aid tilted vertically

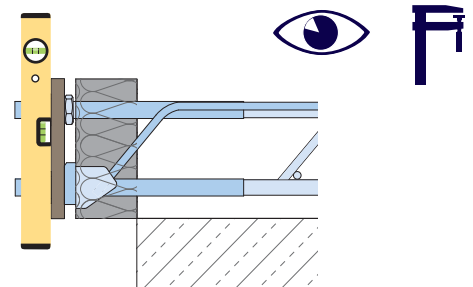

✔ correct: Installation aid vertically aligned

Halfen HIT Steel to Concrete Connector

Installation aid

Notes on the installation aids

Drill templates are available for download.

Alternatively, drill templates are available as PDF files for free download. The templates can be printed and attached to the formwork for measuring and drilling.

When printing the files, ensure the correct scale is set: Page setting should be "actual size" or 100%. The control grid (2x2 cm) should also be checked for correct size after printing the template.

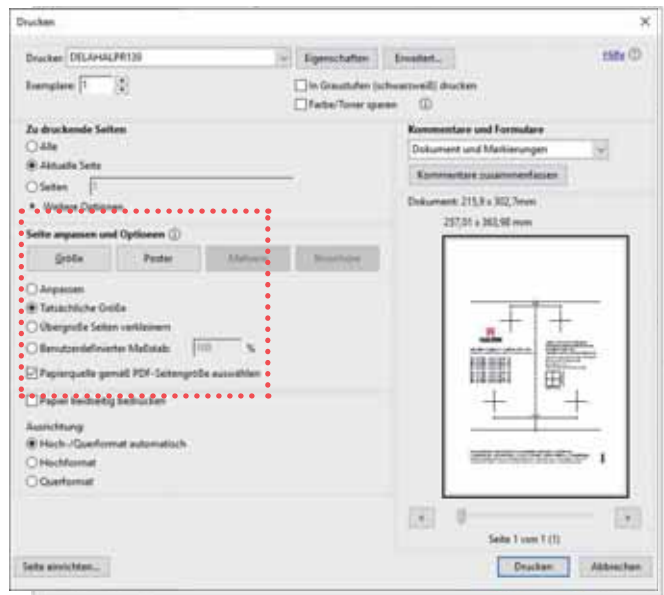
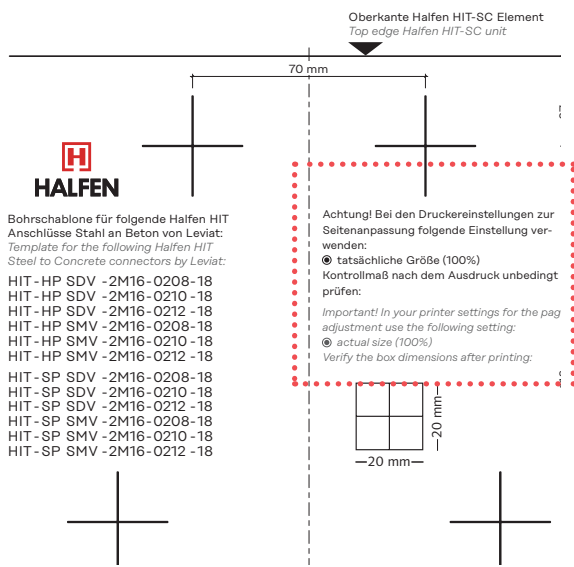

Achtung! Bei den Druckereinstellungen zur Seitenanpassung folgende Einstellung verwenden:
 tatsächliche Größe (100%)
 Kontrollmaß nach dem Ausdruck unbedingt prüfen:
 Important! In your printer settings for the page adjustment use the following setting:
 actual size (100%)
 Verify the box dimensions after printing:

20 mm x 20 mm grid



Page Sizing & Handling

Size Poster Multiple Booklet

Fit

Actual size

Shrink oversized pages

Custom Scale: [100] %

Choose paper source by PDF page size

Print on both sides of paper

Orientation:

Auto portrait/landscape



A free drilling template (.pdf file) is available at:
 ▶ www.halfen.com ▶ Product Ranges ▶ Construction
 ▶ Reinforcement systems ▶ HIT Steel to Concrete Connector
 ▶ Product Information ▶ Installation Instructions



Please note: Ensure the *Actual size* option is active in the *Print* menu when printing the drilling templates. Check the printed templates for correct dimensions!

Halfen HIT Steel to Concrete Connector

HIT-HP SDV, HIT-SP SDV

SDV 1

1

- Connection system for attaching steel elements to reinforced concrete structures
- Transfer of bi-directional bending moments and bi-directional shear loads as well as horizontal forces parallel to the joint



SMV 2

SZV 3



CONSTRUCTION 4

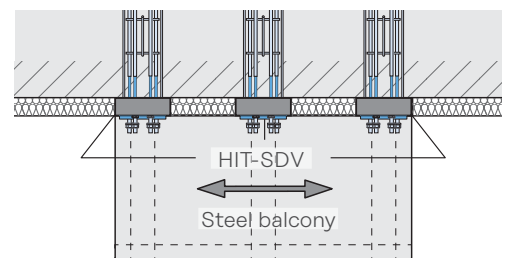
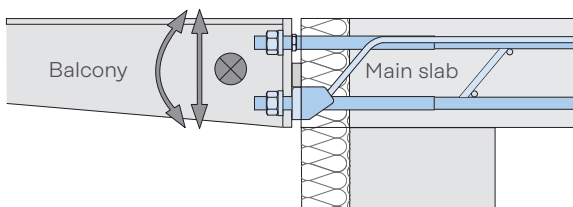

Application: Cantilevered balcony

- HIT-HP SDV – High Performance with 80mm insulation
- HIT-SP SDV – Superior Performance with 120mm insulation

BUILDING PHYSICS 5

Contents	Type	Page
Load range	HIT-HP SDV, HIT-SP SDV	17
Load capacity values	HIT-HP SDV, HIT-SP SDV	18
Product description	HIT-HP SDV, HIT-SP SDV	34
On-site connecting reinforcement	HIT-HP SDV, HIT-SP SDV	36
Deformation	HIT-HP SDV, HIT-SP SDV	38
Torsion spring stiffnesses	HIT-HP SDV, HIT-SP SDV	39
Axial spacings	HIT-HP SDV, HIT-SP SDV	40
Installation instructions	HIT-HP SDV, HIT-SP SDV	42

Halfen HIT Steel to Concrete Connector

HIT-HP SDV, HIT-SP SDV

Load capacity ranges

Combinations of two moment and four shear load capacities are available. The following combinations of tension and shear bars are available for HIT-HP (80mm insulation thickness) and HIT-SP (120mm insulation thickness).

Element width B = 25 cm					
Number and diameter of balcony side connection threads	Number and diameter of tension and compression bars on slab side	Number and diameter of the shear load bars			
		2 ø6	2 ø8	2 ø10	2 ø12
2M12	2ø12	●	●	●	
2M16	2ø14		●	●	●
2M20	2ø16		●	●	●
2M22	2ø20		●	●	●

Design values for selected elements can be found on the following pages ● = HP and SP

Basic types – Ordering example

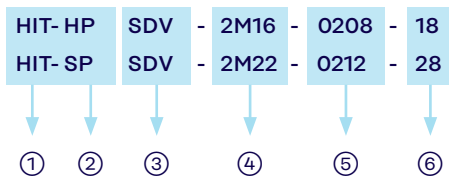

Custom Solutions

Halfen HIT Insulated connections

Our technical support team is available if a custom solution is required for your project.

Contact details: → see back cover of catalogue

Type designation

- ① Product group
- ② Joint spacing 80mm (HP) or 120 mm (SP)
- ③ Connection type
- ④ Moment load range
- ⑤ Shear load range
- ⑥ Element height [cm]

Technical specifications

HIT-HP/HIT-SP	Possible element heights h [cm]	Balcony connection	Main slab			min. concrete cover, slab [mm]	
		Thread	Tension rod [mm]	Compression rod [mm]	Shear load rod [mm]	C _{v,top}	C _{v,bottom}
SDV-2M12-0206	18–28	2 M12	2 ø12	2 ø12	2 ø6	21	34
SDV-2M12-0208		2 M12	2 ø12	2 ø12	2 ø8	21	34
SDV-2M12-0210		2 M12	2 ø12	2 ø12	2 ø10	21	34
SDV-2M16-0208		2 M16	2 ø14	2 ø14	2 ø8	20	33
SDV-2M16-0210		2 M16	2 ø14	2 ø14	2 ø10	20	33
SDV-2M16-0212		2 M16	2 ø14	2 ø14	2 ø12	20	33
SDV-2M20-0210		2 M20	2 ø16	2 ø16	2 ø8	28	28
SDV-2M20-0208		2 M20	2 ø16	2 ø16	2 ø10	28	28
SDV-2M20-0210		2 M20	2 ø16	2 ø16	2 ø12	28	28
SDV-2M22-0208		2 M22	2 ø20	2 ø20	2 ø8	26	26
SDV-2M22-0210		2 M22	2 ø20	2 ø20	2 ø10	26	26
SDV-2M22-0212		2 M22	2 ø20	2 ø20	2 ø12	26	26

1 SDV

2 SMV

3 SZV

4 CONSTRUCTION

5 BUILDING PHYSICS

Halfen HIT Steel to Concrete Connector

HIT-HP SDV

Resistance at ultimate load capacity



Shear capacity / Moment bearing capacity

Concrete strength: C20/25 ≥ C25/30



HIT-HP SDV 2M12-0206	Section A-A $V_{Rd,A}$ [kN]		Section B-B for selected shear load $V_{Rd,B}$ [kN]						M12	
	18.8	18.8	5.0	5.0	10.0	10.0	15.0	15.0	18.8	18.8
Design values	18.8	18.8	5.0	5.0	10.0	10.0	15.0	15.0	18.8	18.8
Element height [mm]	$M_{Rd,A}$ [kNm]		$M_{Rd,B}$ [kNm]							
180	-9.6 4.0	-11.0 4.0	-8.9 4.0	-10.3 4.0	-8.2 4.0	-9.6 4.0	-7.6 4.0	-9.0 4.0	-7.1 4.0	-8.5 4.0
200	-11.0 4.7	-12.9 4.7	-10.3 4.7	-12.1 4.7	-9.5 4.7	-11.4 4.7	-8.8 4.7	-10.6 4.7	-8.2 4.7	-10.1 4.7
220	-12.4 5.4	-14.5 5.4	-11.6 5.4	-13.6 5.4	-10.7 5.4	-12.8 5.4	-9.9 5.4	-12.0 5.4	-9.3 5.4	-11.3 5.4
240	-13.8 6.1	-16.1 6.1	-12.9 6.1	-15.2 6.1	-12.0 6.1	-14.3 6.1	-11.0 6.1	-13.3 6.1	-10.3 6.1	-12.6 6.1
260	-15.2 6.8	-17.7 6.8	-14.2 6.8	-16.7 6.8	-13.2 6.8	-15.7 6.8	-12.2 6.8	-14.7 6.8	-11.4 6.8	-13.9 6.8
280	-16.6 7.5	-19.3 7.5	-15.5 7.5	-18.2 7.5	-14.4 7.5	-17.1 7.5	-13.3 7.5	-16.0 7.5	-12.5 7.5	-15.2 7.5
Element height [mm]	$V_{Rd,y}$ [kN]									
180	±12.8 ±14.1									
200–280	±12.8 ±14.3									

Load bearing capacity values for further types and for concrete strength C30/37 can be found in the type tests at www.halfen.com or on request.
→ See back cover for contact information.



The verification can be performed either in section A-A or in section B-B.

Halfen HIT Steel to Concrete Connector

HIT-HP SDV

Resistance at ultimate load capacity



Shear capacity / Moment bearing capacity

Concrete strength: C20/25 ≥ C25/30



HIT-HP SDV 2M12-0208	Section A-A V _{Rd,A} [kN]		Section B-B for selected shear load V _{Rd,B} [kN]						M12	
	33.5	33.5	10.0	10.0	20.0	20.0	30.0	30.0	33.5	33.5
Design values	-15.4	-15.4	-15.4	-15.4	-15.4	-15.4	-15.4	-15.4	-15.4	-15.4
Element height [mm]	M _{Rd,A} [kNm]		M _{Rd,B} [kNm]							
180	-9.6	-11.0	-8.2	-9.6	-6.9	-8.3	-5.6	-7.0	-5.1	-6.5
	4.0	4.0	1.9	1.9	1.9	1.9	1.9	1.9	1.9	1.9
200	-11.0	-12.9	-9.5	-11.4	-8.0	-9.9	-6.5	-8.4	-6.0	-7.9
	4.7	4.7	2.4	2.4	2.4	2.4	2.4	2.4	2.4	2.4
220	-12.4	-14.5	-10.7	-12.8	-9.1	-11.2	-7.4	-9.5	-6.8	-8.9
	5.4	5.4	2.8	2.8	2.8	2.8	2.8	2.8	2.8	2.8
240	-13.8	-16.1	-12.0	-14.3	-10.1	-12.4	-8.3	-10.6	-7.7	-10.0
	6.1	6.1	3.3	3.3	3.3	3.3	3.3	3.3	3.3	3.3
260	-15.2	-17.7	-13.2	-15.7	-11.2	-13.7	-9.2	-11.7	-8.5	-11.0
	6.8	6.8	3.7	3.7	3.7	3.7	3.7	3.7	3.7	3.7
280	-16.6	-19.3	-14.4	-17.1	-12.2	-15.0	-10.1	-12.8	-9.3	-12.1
	7.5	7.5	4.2	4.2	4.2	4.2	4.2	4.2	4.2	4.2
Element height [mm]	V _{Rd,y} [kN]									
180	±14.5					±14.1				
200	±14.5					±14.4				
220	±14.5					15.9				
240	±14.5					16.2				
260	±14.5					16.2				
280	±14.5					16.2				

Load bearing capacity values for further types and for concrete strength C30/37 can be found in the type tests at www.halfen.com or on request.
 → See back cover for contact information.



The verification can be performed either in section A-A or in section B-B.

Halfen HIT Steel to Concrete Connector

HIT-HP SDV

Resistance at ultimate load capacity



Shear capacity / Moment bearing capacity

Concrete strength: C20/25 ≥ C25/30



HIT-HP SDV 2M12-0210	Section A-A V _{Rd,A} [kN]		Section B-B for selected shear load V _{Rd,B} [kN]						M12	
	Design values	52.3 -15.4	52.3 -15.4	20.0 -15.4	20.0 -15.4	30.0 -15.4	30.0 -15.4	50.0 -15.4	50.0 -15.4	52.3 -15.4
Element height [mm]	M _{Rd,A} [kNm]		M _{Rd,B} [kNm]							
180	-9.6 4.0	-11.0 4.0	-6.9 1.9	-8.3 1.9	-5.6 1.9	-7.0 1.9	-3.0 1.9	-4.4 1.9	-2.6 1.9	-4.0 1.9
200	-11.0 4.7	-12.9 4.7	-8.0 2.4	-9.9 2.4	-6.5 2.4	-8.4 2.4	-3.6 2.4	-5.4 2.4	-3.2 2.4	-5.1 2.4
220	-12.4 5.4	-14.5 5.4	-9.1 2.8	-11.2 2.8	-7.4 2.8	-9.5 2.8	-4.1 2.8	-6.2 2.8	-3.7 2.8	-5.8 2.8
240	-13.8 6.1	-16.1 6.1	-10.1 3.3	-12.4 3.3	-8.3 3.3	-10.6 3.3	-4.7 3.3	-6.9 3.3	-4.2 3.3	-6.5 3.3
260	-15.2 6.8	-17.7 6.8	-11.2 3.7	-13.7 3.7	-9.2 3.7	-11.7 3.7	-5.2 3.7	-7.7 3.7	-4.7 3.7	-7.2 3.7
280	-16.6 7.5	-19.3 7.5	-12.2 4.2	-15.0 4.2	-10.1 4.2	-12.8 4.2	-5.7 4.2	-8.5 4.2	-5.2 4.2	-8.0 4.2
Element height [mm]	V _{Rd,y} [kN]									
180	±16.4 ±14.1									
200	±16.4 ±14.4									
220	±16.4 15.9									
240	±16.4 17.1									
260	±16.4 18.1									
280	±16.4 18.3									

Load bearing capacity values for further types and for concrete strength C30/37 can be found in the type tests at www.halfen.com or on request.
→ See back cover for contact information.



The verification can be performed either in section A-A or in section B-B.

Halfen HIT Steel to Concrete Connector

HIT-HP SDV

Resistance at ultimate load capacity



Shear capacity / Moment bearing capacity

Concrete strength: C20/25 ≥ C25/30



1 SDV

HIT-HP SDV 2M16-0208	Section A-A V _{Rd,A} [kN]		Section B-B for selected shear load V _{Rd,B} [kN]						M16	
	33.5	33.5	10.0	10.0	20.0	20.0	30.0	30.0	33.5	33.5
Design values	-15.4	-15.4	-15.4	-15.4	-15.4	-15.4	-15.4	-15.4	-15.4	-15.4
Element height [mm]	M _{Rd,A} [kNm]		M _{Rd,B} [kNm]							
180	-13.9	-15.1	-9.7	-10.9	-8.3	-9.6	-6.9	-8.2	-6.6	-7.8
	12.5	14.7	10.3	12.5	10.3	12.5	10.3	12.5	10.3	12.5
200	-16.0	-17.8	-11.3	-13.1	-9.7	-11.6	-8.1	-10.0	-7.8	-9.6
	14.6	17.1	12.2	14.7	12.2	14.7	12.2	14.7	12.2	14.7
220	-18.1	-20.5	-12.9	-15.3	-11.1	-13.6	-9.4	-11.8	-9.0	-11.4
	16.7	19.5	14.0	16.9	14.0	16.9	14.0	16.9	14.0	16.9
240	-20.2	-23.2	-14.5	-17.5	-12.6	-15.6	-10.7	-13.7	-10.2	-13.2
	18.8	22.0	15.9	19.1	15.9	19.1	15.9	19.1	15.9	19.1
260	-22.3	-25.8	-16.1	-19.6	-14.0	-17.6	-11.9	-15.5	-11.5	-15.0
	20.9	24.4	17.7	21.2	17.7	21.2	17.7	21.2	17.7	21.2
280	-24.4	-28.4	-17.7	-21.7	-15.4	-19.5	-13.2	-17.3	-12.7	-16.8
	23.0	26.9	19.6	23.4	19.6	23.4	19.6	23.4	19.6	23.4
Element height [mm]	V _{Rd,y} [kN]									
180-280	±15.3					±17.1				

2 SMV

3 SZV

Load bearing capacity values for further types and for concrete strength C30/37 can be found in the type tests at www.halfen.com or on request.
→ See back cover for contact information.

4 CONSTRUCTION

HIT-HP SDV 2M16-0210	Section A-A V _{Rd,A} [kN]		Section B-B for selected shear load V _{Rd,B} [kN]						M16	
	52.3	52.3	30.0	30.0	40.0	40.0	50.0	50.0	52.3	52.3
Design values	-15.4	-15.4	-15.4	-15.4	-15.4	-15.4	-15.4	-15.4	-15.4	-15.4
Element height [mm]	M _{Rd,A} [kNm]		M _{Rd,B} [kNm]							
180	-13.9	-15.1	-9.7	-10.9	-8.3	-9.6	-6.9	-8.2	-6.6	-7.8
	12.5	14.7	12.5	14.7	12.5	14.7	12.5	14.7	12.5	14.7
200	-16.0	-17.8	-11.3	-13.1	-9.7	-11.6	-8.1	-10.0	-7.8	-9.6
	14.6	17.1	14.6	17.1	14.6	17.1	14.6	17.1	14.6	17.1
220	-18.1	-20.5	-12.9	-15.3	-11.1	-13.6	-9.4	-11.8	-9.0	-11.4
	16.7	19.5	16.7	19.5	16.7	19.5	16.7	19.5	16.7	19.5
240	-20.2	-23.2	-14.5	-17.5	-12.6	-15.6	-10.7	-13.7	-10.2	-13.2
	18.8	22.0	18.8	22.0	18.8	22.0	18.8	22.0	18.8	22.0
260	-22.3	-25.8	-16.1	-19.6	-14.0	-17.6	-11.9	-15.5	-11.5	-15.0
	20.9	24.4	20.9	24.4	20.9	24.4	20.9	24.4	20.9	24.4
280	-24.4	-28.4	-17.7	-21.7	-15.4	-19.5	-13.2	-17.3	-12.7	-16.8
	23.0	26.9	23.0	26.9	23.0	26.9	23.0	26.9	23.0	26.9
Element height [mm]	V _{Rd,y} [kN]									
180-280	±17.2					±19.2				

5 BUILDING PHYSICS

Load bearing capacity values for further types and for concrete strength C30/37 can be found in the type tests at www.halfen.com or on request.
→ See back cover for contact information.

Halfen HIT Steel to Concrete Connector

HIT-HP SDV

Resistance at ultimate load capacity



Shear capacity / Moment bearing capacity

Concrete strength: C20/25 ≥ C25/30



HIT-HP SDV 2M16-0212	Section A-A V _{Rd,A} [kN]		Section B-B for selected shear load V _{Rd,B} [kN]								M16
	Design values	75.3 -15.4	75.3 -15.4	50.0 -15.4	50.0 -15.4	60.0 -15.4	60.0 -15.4	70.0 -15.4	70.0 -15.4	75.3 -15.4	75.3 -15.4
Element height [mm]	M _{Rd,A} [kNm]		M _{Rd,B} [kNm]								
180	-13.9 12.5	-15.1 14.7	-6.9 10.3	-8.2 12.5	-5.5 10.3	-6.8 12.5	-4.1 10.3	-5.4 12.5	-3.4 10.3	-4.6 12.5	
200	-16.0 14.6	-17.8 17.1	-8.1 12.2	-10.0 14.7	-6.6 12.2	-8.4 14.7	-5.0 12.2	-6.9 14.7	-4.2 12.2	-6.0 14.7	
220	-18.1 16.7	-20.5 19.5	-9.4 14.0	-11.8 16.9	-7.7 14.0	-10.1 16.9	-5.9 14.0	-8.4 16.9	-5.0 14.0	-7.5 16.9	
240	-20.2 18.8	-23.2 22.0	-10.7 15.9	-13.7 19.1	-8.8 15.9	-11.8 19.1	-6.9 15.9	-9.9 19.1	-5.9 15.9	-8.9 19.1	
260	-22.3 20.9	-25.8 24.4	-11.9 17.7	-15.5 21.2	-9.9 17.7	-13.4 21.2	-7.8 17.7	-11.4 21.2	-6.7 17.7	-10.3 21.2	
280	-24.4 23.0	-28.4 26.9	-13.2 19.6	-17.3 23.4	-11.0 19.6	-15.0 23.4	-8.7 19.6	-12.8 23.4	-7.5 19.6	-11.6 23.4	
Element height [mm]	V _{Rd,y} [kN]										
180–280	±19.2 ±21.4										

Load bearing capacity values for further types and for concrete strength C30/37 can be found in the type tests at www.halfen.com or on request.
→ See back cover for contact information.

HIT-HP SDV 2M20-0208	Section A-A V _{Rd,A} [kN]		Section B-B for selected shear load V _{Rd,B} [kN]								M20
	Design values	33.5 -15.4	33.5 -15.4	10.0 -15.4	10.0 -15.4	20.0 -15.4	20.0 -15.4	30.0 -15.4	30.0 -15.4	33.5 -15.4	33.5 -15.4
Element height [mm]	M _{Rd,A} [kNm]		M _{Rd,B} [kNm]								
180	-18.9 11.9	-18.9 12.8	-17.6 9.9	-17.6 10.8	-16.2 9.9	-16.2 10.8	-14.9 9.9	-14.9 10.8	-14.5 9.9	-14.5 10.8	
200	-22.4 13.9	-22.4 15.2	-20.9 11.6	-20.9 12.9	-19.4 11.6	-19.4 12.9	-17.9 11.6	-17.9 12.9	-17.4 11.6	-17.4 12.9	
220	-25.9 15.8	-25.9 17.5	-24.2 13.2	-24.2 15.0	-22.6 13.2	-22.6 15.0	-20.9 13.2	-20.9 15.0	-20.3 13.2	-20.3 15.0	
240	-29.4 17.7	-29.4 19.9	-27.6 14.9	-27.6 17.1	-25.7 14.9	-25.7 17.1	-23.9 14.9	-23.9 17.1	-23.3 14.9	-23.3 17.1	
260	-32.9 19.6	-32.9 22.3	-30.9 16.5	-30.9 19.2	-28.9 16.5	-28.9 19.2	-26.9 16.5	-26.9 19.2	-26.2 16.5	-26.2 19.2	
280	-36.4 21.5	-36.4 24.6	-34.2 18.2	-34.2 21.3	-32.1 18.2	-32.1 21.3	-29.9 18.2	-29.9 21.3	-29.1 18.2	-29.1 21.3	
Element height [mm]	V _{Rd,y} [kN]										
180–280	±16.2 ±18.2										

Load bearing capacity values for further types and for concrete strength C30/37 can be found in the type tests at www.halfen.com or on request.
→ See back cover for contact information.

Halfen HIT Steel to Concrete Connector

HIT-HP SDV

Resistance at ultimate load capacity



Shear capacity / Moment bearing capacity

Concrete strength: C20/25 ≥ C25/30



HIT-HP SDV 2M20-0210	Section A-A V _{Rd,A} [kN]		Section B-B for selected shear load V _{Rd,B} [kN]						M20	
Design values	52.3	52.3	30.0	30.0	40.0	40.0	50.0	50.0	52.3	52.3
	-15.4	-15.4	-15.4	-15.4	-15.4	-15.4	-15.4	-15.4	-15.4	-15.4
Element height [mm]	M _{Rd,A} [kNm]		M _{Rd,B} [kNm]							
180	-18.9	-18.9	-14.9	-14.9	-13.6	-13.6	-12.3	-12.3	-12.0	-12.0
	11.9	12.8	9.9	10.8	9.9	10.8	9.9	10.8	9.9	10.8
200	-22.4	-22.4	-17.9	-17.9	-16.4	-16.4	-14.9	-14.9	-14.6	-14.6
	13.9	15.2	11.6	12.9	11.6	12.9	11.6	12.9	11.6	12.9
220	-25.9	-25.9	-20.9	-20.9	-19.3	-19.3	-17.6	-17.6	-17.2	-17.2
	15.8	17.5	13.2	15.0	13.2	15.0	13.2	15.0	13.2	15.0
240	-29.4	-29.4	-23.9	-23.9	-22.1	-22.1	-20.3	-20.3	-19.8	-19.8
	17.7	19.9	14.9	17.1	14.9	17.1	14.9	17.1	14.9	17.1
260	-32.9	-32.9	-26.9	-26.9	-24.9	-24.9	-22.9	-22.9	-22.5	-22.5
	19.6	22.3	16.5	19.2	16.5	19.2	16.5	19.2	16.5	19.2
280	-36.4	-36.4	-29.9	-29.9	-27.7	-27.7	-25.6	-25.6	-25.1	-25.1
	21.5	24.6	18.2	21.3	18.2	21.3	18.2	21.3	18.2	21.3
Element height [mm]	V _{Rd,y} [kN]									
180–280	±18.2 ±20.3									

Load bearing capacity values for further types and for concrete strength C30/37 can be found in the type tests at www.halfen.com or on request.
→ See back cover for contact information.

HIT-HP SDV 2M20-0212	Section A-A V _{Rd,A} [kN]		Section B-B for selected shear load V _{Rd,B} [kN]						M20	
Design values	75.3	75.3	50.0	50.0	60.0	60.0	70.0	70.0	75.3	75.3
	-15.4	-15.4	-15.4	-15.4	-15.4	-15.4	-15.4	-15.4	-15.4	-15.4
Element height [mm]	M _{Rd,A} [kNm]		M _{Rd,B} [kNm]							
180	-18.9	-18.9	-12.3	-12.3	-11.0	-11.0	-9.7	-9.7	-9.0	-9.0
	11.9	12.8	9.9	10.8	9.9	10.8	9.9	10.8	9.9	10.8
200	-22.4	-22.4	-14.9	-14.9	-13.5	-13.5	-12.0	-12.0	-11.2	-11.2
	13.9	15.2	11.6	12.9	11.6	12.9	11.6	12.9	11.6	12.9
220	-25.9	-25.9	-17.6	-17.6	-16.0	-16.0	-14.3	-14.3	-13.4	-13.4
	15.8	17.5	13.2	15.0	13.2	15.0	13.2	15.0	13.2	15.0
240	-29.4	-29.4	-20.3	-20.3	-18.4	-18.4	-16.6	-16.6	-15.6	-15.6
	17.7	19.9	14.9	17.1	14.9	17.1	14.9	17.1	14.9	17.1
260	-32.9	-32.9	-22.9	-22.9	-20.9	-20.9	-18.9	-18.9	-17.9	-17.9
	19.6	22.3	16.5	19.2	16.5	19.2	16.5	19.2	16.5	19.2
280	-36.4	-36.4	-25.6	-25.6	-23.4	-23.4	-21.3	-21.3	-20.1	-20.1
	21.5	24.6	18.2	21.3	18.2	21.3	18.2	21.3	18.2	21.3
Element height [mm]	V _{Rd,y} [kN]									
180–280	±20.2 ±22.6									

Load bearing capacity values for further types and for concrete strength C30/37 can be found in the type tests at www.halfen.com or on request.
→ See back cover for contact information.

1 SDV

2 SMV

3 SZV

4 CONSTRUCTION

5 BUILDING PHYSICS

Halfen HIT Steel to Concrete Connector

HIT-HP SDV

Resistance at ultimate load capacity



Shear capacity / Moment bearing capacity

Concrete strength: C20/25 ≥ C25/30



HIT-HP SDV 2M22-0208	Section A-A V _{Rd,A} [kN]		Section B-B for selected shear load V _{Rd,B} [kN]								M22
	33.5	33.5	10.0	10.0	20.0	20.0	30.0	30.0	33.5	33.5	
Design values	-15.4	-15.4	-15.4	-15.4	-15.4	-15.4	-15.4	-15.4	-15.4	-15.4	-15.4
Element height [mm]	M _{Rd,A} [kNm]		M _{Rd,B} [kNm]								
180	-27.4	-29.5	-26.1	-28.2	-24.8	-26.9	-23.4	-25.5	-23.0	-25.1	
	16.1	17.6	14.1	15.6	14.1	15.6	14.1	15.6	14.1	15.6	
200	-32.5	-35.0	-31.0	-33.5	-29.5	-32.0	-28.0	-30.5	-27.5	-30.0	
	18.7	20.9	16.4	18.6	16.4	18.6	16.4	18.6	16.4	18.6	
220	-37.1	-40.4	-35.4	-38.8	-33.7	-37.1	-32.1	-35.5	-31.5	-34.9	
	21.5	24.2	18.9	21.6	18.9	21.6	18.9	21.6	18.9	21.6	
240	-41.4	-45.7	-39.6	-43.9	-37.7	-42.1	-35.9	-40.2	-35.3	-39.6	
	24.2	27.4	21.4	24.6	21.4	24.6	21.4	24.6	21.4	24.6	
260	-45.6	-50.2	-43.6	-48.3	-41.6	-46.3	-39.6	-44.3	-38.9	-43.6	
	26.9	30.7	23.9	27.6	23.9	27.6	23.9	27.6	23.9	27.6	
280	-49.7	-54.7	-47.5	-52.5	-45.3	-50.4	-43.2	-48.2	-42.4	-47.5	
	29.7	33.9	26.4	30.6	26.4	30.6	26.4	30.6	26.4	30.6	
Element height [mm]	V _{Rd,y} [kN]										
180–280	±16.5 ±18.5										

Load bearing capacity values for further types and for concrete strength C30/37 can be found in the type tests at www.halfen.com or on request.
→ See back cover for contact information.

HIT-HP SDV 2M22-0210	Section A-A V _{Rd,A} [kN]		Section B-B for selected shear load V _{Rd,B} [kN]								M22
	52.3	52.3	30.0	30.0	40.0	40.0	50.0	50.0	52.3	52.3	
Design values	-15.4	-15.4	-15.4	-15.4	-15.4	-15.4	-15.4	-15.4	-15.4	-15.4	
Element height [mm]	M _{Rd,A} [kNm]		M _{Rd,B} [kNm]								
180	-27.4	-29.5	-23.4	-25.5	-22.1	-24.2	-20.8	-22.9	-20.5	-22.6	
	16.1	17.6	14.1	15.6	14.1	15.6	14.1	15.6	14.1	15.6	
200	-32.5	-35.0	-28.0	-30.5	-26.5	-29.0	-25.0	-27.5	-24.7	-27.2	
	18.7	20.9	16.4	18.6	16.4	18.6	16.4	18.6	16.4	18.6	
220	-37.1	-40.4	-32.1	-35.5	-30.4	-33.8	-28.8	-32.2	-28.4	-31.8	
	21.5	24.2	18.9	21.6	18.9	21.6	18.9	21.6	18.9	21.6	
240	-41.4	-45.7	-35.9	-40.2	-34.1	-38.4	-32.3	-36.6	-31.8	-36.2	
	24.2	27.4	21.4	24.6	21.4	24.6	21.4	24.6	21.4	24.6	
260	-45.6	-50.2	-39.6	-44.3	-37.6	-42.3	-35.6	-40.3	-35.2	-39.8	
	26.9	30.7	23.9	27.6	23.9	27.6	23.9	27.6	23.9	27.6	
280	-49.7	-54.7	-43.2	-48.2	-41.0	-46.1	-38.9	-43.9	-38.4	-43.4	
	29.7	33.9	26.4	30.6	26.4	30.6	26.4	30.6	26.4	30.6	
Element height [mm]	V _{Rd,y} [kN]										
180–280	±18.5 ±20.7										

Load bearing capacity values for further types and for concrete strength C30/37 can be found in the type tests at www.halfen.com or on request.
→ See back cover for contact information.

Halfen HIT Steel to Concrete Connector

HIT-HP SDV

Resistance at ultimate load capacity



Shear capacity / Moment bearing capacity

Concrete strength: C20/25 ≥ C25/30



HIT-HP SDV 2M22-0212	Section A-A $V_{Rd,A}$ [kN]		Section B-B for selected shear load $V_{Rd,B}$ [kN]								M22
	75.3	75.3	50.0	50.0	60.0	60.0	70.0	70.0	75.3	75.3	
Design values	-15.4	-15.4	-15.4	-15.4	-15.4	-15.4	-15.4	-15.4	-15.4	-15.4	-15.4
Element height [mm]	$M_{Rd,A}$ [kNm]		$M_{Rd,B}$ [kNm]								
180	-27.4	-29.5	-20.8	-22.9	-19.5	-21.6	-18.2	-20.3	-17.5	-19.6	
	16.1	17.6	14.1	15.6	14.1	15.6	14.1	15.6	14.1	15.6	
200	-32.5	-35.0	-25.0	-27.5	-23.6	-26.1	-22.1	-24.6	-21.3	-23.8	
	18.7	20.9	16.4	18.6	16.4	18.6	16.4	18.6	16.4	18.6	
220	-37.1	-40.4	-28.8	-32.2	-27.1	-30.5	-25.5	-28.9	-24.6	-28.0	
	21.5	24.2	18.9	21.6	18.9	21.6	18.9	21.6	18.9	21.6	
240	-41.4	-45.7	-32.3	-36.6	-30.4	-34.8	-28.6	-33.0	-27.6	-32.0	
	24.2	27.4	21.4	24.6	21.4	24.6	21.4	24.6	21.4	24.6	
260	-45.6	-50.2	-35.6	-40.3	-33.6	-38.3	-31.7	-36.3	-30.6	-35.3	
	26.9	30.7	23.9	27.6	23.9	27.6	23.9	27.6	23.9	27.6	
280	-49.7	-54.7	-38.9	-43.9	-36.7	-41.7	-34.5	-39.6	-33.4	-38.4	
	29.7	33.9	26.4	30.6	26.4	30.6	26.4	30.6	26.4	30.6	
Element height [mm]	$V_{Rd,y}$ [kN]										
180–280	±20.5 ±23.0										

Load bearing capacity values for further types and for concrete strength C30/37 can be found in the type tests at www.halfen.com or on request.
→ See back cover for contact information.

1 SDV

2 SMV

3 SZV

4 KONSTRUKTION

5 BAUPHYSIK

Halfen HIT Steel to Concrete Connector

HIT-SP SDV

Resistance at ultimate load capacity



Shear capacity / Moment bearing capacity

Concrete strength: C20/25 ≥ C25/30



HIT-SP SDV 2M12-0206	Section A-A $V_{Rd,A}$ [kN]		Section B-B for selected shear load $V_{Rd,B}$ [kN]								M12
	Design values	15.8	15.8	5.0	5.0	10.0	10.0	15.0	15.0	15.8	15.8
Element height [mm]	$M_{Rd,A}$ [kNm]		$M_{Rd,B}$ [kNm]								
180	-9.6 4.0	-11.0 4.0	-8.7 4.0	-10.1 4.0	-7.8 4.0	-9.2 4.0	-6.9 4.0	-8.3 4.0	-6.8 4.0	-8.2 4.0	
200	-11.0 4.7	-12.9 4.7	-10.0 4.7	-11.9 4.7	-9.0 4.7	-10.9 4.7	-8.0 4.7	-9.9 4.7	-7.9 4.7	-9.7 4.7	
220	-12.4 5.4	-14.5 5.4	-11.3 5.4	-13.4 5.4	-10.2 5.4	-12.2 5.4	-9.1 5.4	-11.1 5.4	-8.9 5.4	-10.9 5.4	
240	-13.8 6.1	-16.1 6.1	-12.6 6.1	-14.8 6.1	-11.3 6.1	-13.6 6.1	-10.1 6.1	-12.4 6.1	-9.9 6.1	-12.2 6.1	
260	-15.2 6.8	-17.7 6.8	-13.8 6.8	-16.3 6.8	-12.5 6.8	-15.0 6.8	-11.1 6.8	-13.6 6.8	-10.9 6.8	-13.4 6.8	
280	-16.6 7.5	-19.3 7.5	-15.1 7.5	-17.8 7.5	-13.6 7.5	-16.3 7.5	-12.1 7.5	-14.9 7.5	-11.9 7.5	-14.6 7.5	
Element height [mm]	$V_{Rd,y}$ [kN]										
180	±12.8 ±10.0										
200	±12.8 ±10.1										
220	±12.8 ±11.3										
240	±12.8 ±12.2										
260	±12.8 ±12.9										
280	±12.8 ±13.4										

Load bearing capacity values for further types and for concrete strength C30/37 can be found in the type tests at www.halfen.com or on request.
→ See back cover for contact information.

Halfen HIT Steel to Concrete Connector

HIT-SP SDV

Resistance at ultimate load capacity



Shear capacity / Moment bearing capacity

Concrete strength: C20/25 ≥ C25/30



HIT-SP SDV 2M12-0208	Section A-A V _{Rd,A} [kN]		Section B-B for selected shear load V _{Rd,B} [kN]						M12 	
	28.1 -15.4	28.1 -15.4	10.0 -15.4	10.0 -15.4	20.0 -15.4	20.0 -15.4	25.0 -15.4	25.0 -15.4	28.1 -15.4	28.1 -15.4
Element height [mm]	M _{Rd,A} [kNm]		M _{Rd,B} [kNm]							
180	-9.6	-11.0	-7.8	-9.2	-6.1	-7.5	-5.2	-6.6	-4.6	-6.0
	4.0	4.0	1.3	1.3	1.3	1.3	1.3	1.3	1.3	1.3
200	-11.0	-12.9	-9.0	-10.9	-7.0	-8.9	-6.0	-7.9	-5.4	-7.3
	4.7	4.7	1.6	1.6	1.6	1.6	1.6	1.6	1.6	1.6
220	-12.4	-14.5	-10.2	-12.2	-7.9	-10.0	-6.8	-8.9	-6.1	-8.2
	5.4	5.4	2.0	2.0	2.0	2.0	2.0	2.0	2.0	2.0
240	-13.8	-16.1	-11.3	-13.6	-8.9	-11.1	-7.6	-9.9	-6.9	-9.1
	6.1	6.1	2.3	2.3	2.3	2.3	2.3	2.3	2.3	2.3
260	-15.2	-17.7	-12.5	-15.0	-9.8	-12.3	-8.4	-10.9	-7.6	-10.1
	6.8	6.8	2.7	2.7	2.7	2.7	2.7	2.7	2.7	2.7
280	-16.6	-19.3	-13.6	-16.3	-10.7	-13.4	-9.2	-11.9	-8.3	-11.0
	7.5	7.5	3.0	3.0	3.0	3.0	3.0	3.0	3.0	3.0
Element height [mm]	V _{Rd,y} [kN]									
180	±14.5 ±10.0									
200	±14.5 ±10.1									
220	±14.5 ±11.3									
240	±14.5 ±12.2									
260	±14.5 ±12.9									
280	±14.5 ±13.4									

Load bearing capacity values for further types and for concrete strength C30/37 can be found in the type tests at www.halfen.com or on request.
→ See back cover for contact information.

1 SDV

2 SMV

3 SZV

4 CONSTRUCTION

5 BUILDING PHYSICS

Halfen HIT Steel to Concrete Connector

HIT-SP SDV

Resistance at ultimate load capacity



Shear capacity / Moment bearing capacity

Concrete strength: C20/25 ≥ C25/30



HIT-SP SDV 2M12-0210	Section A-A V _{Rd,A} [kN]		Section B-B for selected shear load V _{Rd,B} [kN]								M12
	Design values	43.9 -15.4	52.3 -15.4	20.0 -15.4	20.0 -15.4	30.0 -15.4	30.0 -15.4	40.0 -15.4	40.0 -15.4	43.9 -15.4	43.9 -15.4
Element height [mm]	M _{Rd,A} [kNm]		M _{Rd,B} [kNm]								
180	-9.6 4.0	-11.0 4.0	-6.1 1.3	-7.5 1.3	-4.3 1.3	-5.7 1.3	-2.6 1.3	-4.0 1.3	-1.9 1.3	-3.3 1.3	
200	-11.0 4.7	-12.9 4.7	-7.0 1.6	-8.9 1.6	-5.0 1.6	-6.9 1.6	-3.0 1.6	-4.9 1.6	-2.3 1.6	-4.1 1.6	
220	-12.4 5.4	-14.5 5.4	-7.9 2.0	-10.0 2.0	-5.7 2.0	-7.8 2.0	-3.5 2.0	-5.6 2.0	-2.6 2.0	-4.7 2.0	
240	-13.8 6.1	-16.1 6.1	-8.9 2.3	-11.1 2.3	-6.4 2.3	-8.7 2.3	-3.9 2.3	-6.2 2.3	-2.9 2.3	-5.2 2.3	
260	-15.2 6.8	-17.7 6.8	-9.8 2.7	-12.3 2.7	-7.1 2.7	-9.6 2.7	-4.3 2.7	-6.9 2.7	-3.3 2.7	-5.8 2.7	
280	-16.6 7.5	-19.3 7.5	-10.7 3.0	-13.4 3.0	-7.7 3.0	-10.5 3.0	-4.8 3.0	-7.5 3.0	-3.6 3.0	-6.4 3.0	
Element height [mm]	V _{Rd,y} [kN]										
180	±16.4 ±10.0										
200	±16.4 ±10.1										
220	±16.4 ±11.3										
240	±16.4 ±12.2										
260	±16.4 ±12.9										
280	±16.4 ±13.4										

Load bearing capacity values for further types and for concrete strength C30/37 can be found in the type tests at www.halfen.com or on request.
→ See back cover for contact information.

Halfen HIT Steel to Concrete Connector

HIT-SP SDV

Resistance at ultimate load capacity



Shear capacity / Moment bearing capacity

Concrete strength: C20/25 ≥ C25/30



HIT-SP SDV 2M16-0208	Section A-A V _{Rd,A} [kN]		Section B-B for selected shear load V _{Rd,B} [kN]								M16
	28.1 -15.4	28.1 -15.4	10.0 -15.4	10.0 -15.4	20.0 -15.4	20.0 -15.4	25.0 -15.4	25.0 -15.4	28.1 -15.4	28.1 -15.4	
Element height [mm]	M _{Rd,A} [kNm]		M _{Rd,B} [kNm]								
180	-13.9	-15.1	-12.0	-13.3	-10.2	-11.5	-9.3	-10.6	-8.7	-10.0	
	12.5	14.7	9.7	11.9	9.7	11.9	9.7	11.9	9.7	11.9	
200	-16.0	-17.8	-13.9	-15.7	-11.8	-13.7	-10.8	-12.6	-10.2	-12.0	
	14.6	17.1	11.4	13.9	11.4	13.9	11.4	13.9	11.4	13.9	
220	-18.1	-20.5	-15.8	-18.2	-13.5	-15.9	-12.3	-14.7	-11.6	-14.0	
	16.7	19.5	13.2	16.0	13.2	16.0	13.2	16.0	13.2	16.0	
240	-20.2	-23.2	-17.6	-20.6	-15.1	-18.1	-13.8	-16.8	-13.0	-16.0	
	18.8	22.0	14.9	18.1	14.9	18.1	14.9	18.1	14.9	18.1	
260	-22.3	-25.8	-19.5	-23.1	-16.7	-20.3	-15.3	-18.9	-14.5	-18.0	
	20.9	24.4	16.6	20.2	16.6	20.2	16.6	20.2	16.6	20.2	
280	-24.4	-28.4	-21.3	-25.4	-18.3	-22.4	-16.8	-20.9	-15.9	-20.0	
	23.0	26.9	18.4	22.2	18.4	22.2	18.4	22.2	18.4	22.2	
Element height [mm]	V _{Rd,y} [kN]										
180–280	±15.3 ±17.1										

Load bearing capacity values for further types and for concrete strength C30/37 can be found in the type tests at www.halfen.com or on request.
→ See back cover for contact information.

1 SDV

2 SMV

3 SZV

4 KONSTRUKTION

5 BAUPHYSIK

Halfen HIT Steel to Concrete Connector

HIT-SP SDV

Resistance at ultimate load capacity



Shear capacity / Moment bearing capacity

Concrete strength: C20/25 ≥ C25/30



HIT-SP SDV 2M16-0210	Section A-A V _{Rd,A} [kN]		Section B-B for selected shear load V _{Rd,B} [kN]								M16
	Design values	43.9	43.9	25.0	25.0	30.0	30.0	40.0	40.0	43.9	
	-15.4	-15.4	-15.4	-15.4	-15.4	-15.4	-15.4	-15.4	-15.4	-15.4	
Element height [mm]	M _{Rd,A} [kNm]		M _{Rd,B} [kNm]								
180	-13.9	-15.1	-9.3	-10.6	-8.4	-9.7	-6.6	-7.8	-5.8	-7.1	
	12.5	14.7	9.7	11.9	9.7	11.9	9.7	11.9	9.7	11.9	
200	-16.0	-17.8	-10.8	-12.6	-9.8	-11.6	-7.7	-9.6	-6.9	-8.7	
	14.6	17.1	11.4	13.9	11.4	13.9	11.4	13.9	11.4	13.9	
220	-18.1	-20.5	-12.3	-14.7	-11.2	-13.6	-8.9	-11.3	-8.0	-10.4	
	16.7	19.5	13.2	16.0	13.2	16.0	13.2	16.0	13.2	16.0	
240	-20.2	-23.2	-13.8	-16.8	-12.5	-15.5	-10.0	-13.0	-9.0	-12.0	
	18.8	22.0	14.9	18.1	14.9	18.1	14.9	18.1	14.9	18.1	
260	-22.3	-25.8	-15.3	-18.9	-13.9	-17.5	-11.1	-14.7	-10.1	-13.6	
	20.9	24.4	16.6	20.2	16.6	20.2	16.6	20.2	16.6	20.2	
280	-24.4	-28.4	-16.8	-20.9	-15.3	-19.4	-12.3	-16.4	-11.1	-15.2	
	23.0	26.9	18.4	22.2	18.4	22.2	18.4	22.2	18.4	22.2	
Element height [mm]	V _{Rd,y} [kN]										
180–280	±17.2 ±19.2										

Load bearing capacity values for further types and for concrete strength C30/37 can be found in the type tests at www.halfen.com or on request.
→ See back cover for contact information.

HIT-SP SDV 2M16-0212	Section A-A V _{Rd,A} [kN]		Section B-B for selected shear load V _{Rd,B} [kN]								M16
	Design values	56.8	56.8	30.0	30.0	40.0	40.0	50.0	50.0	56.8	
	-15.4	-15.4	-15.4	-15.4	-15.4	-15.4	-15.4	-15.4	-15.4	-15.4	
Element height [mm]	M _{Rd,A} [kNm]		M _{Rd,B} [kNm]								
180	-13.9	-15.1	-8.4	-9.7	-6.6	-7.8	-4.7	-6.0	-3.5	-4.8	
	12.5	14.7	9.7	11.9	9.7	11.9	9.7	11.9	9.7	11.9	
200	-16.0	-17.8	-9.8	-11.6	-7.7	-9.6	-5.6	-7.5	-4.2	-6.1	
	14.6	17.1	11.4	13.9	11.4	13.9	11.4	13.9	11.4	13.9	
220	-18.1	-20.5	-11.2	-13.6	-8.9	-11.3	-6.6	-9.0	-5.0	-7.4	
	16.7	19.5	13.2	16.0	13.2	16.0	13.2	16.0	13.2	16.0	
240	-20.2	-23.2	-12.5	-15.5	-10.0	-13.0	-7.5	-10.5	-5.7	-8.7	
	18.8	22.0	14.9	18.1	14.9	18.1	14.9	18.1	14.9	18.1	
260	-22.3	-25.8	-13.9	-17.5	-11.1	-14.7	-8.4	-11.9	-6.5	-10.1	
	20.9	24.4	16.6	20.2	16.6	20.2	16.6	20.2	16.6	20.2	
280	-24.4	-28.4	-15.3	-19.4	-12.3	-16.4	-9.3	-13.4	-7.2	-11.3	
	23.0	26.9	18.4	22.2	18.4	22.2	18.4	22.2	18.4	22.2	
Element height [mm]	V _{Rd,y} [kN]										
180–280	±19.2 ±21.4										

Load bearing capacity values for further types and for concrete strength C30/37 can be found in the type tests at www.halfen.com or on request.
→ See back cover for contact information.

Halfen HIT Steel to Concrete Connector

HIT-SP SDV

Resistance at ultimate load capacity



Shear capacity / Moment bearing capacity

Concrete strength: C20/25 ≥ C25/30



HIT-SP SDV 2M20-0208	Section A-A $V_{Rd,A}$ [kN]		Section B-B for selected shear load $V_{Rd,B}$ [kN]								M20
	28.1 -15.4	28.1 -15.4	10.0 -15.4	10.0 -15.4	20.0 -15.4	20.0 -15.4	25.0 -15.4	25.0 -15.4	28.1 -15.4	28.1 -15.4	
Element height [mm]	$M_{Rd,A}$ [kNm]		$M_{Rd,B}$ [kNm]								
180	-18.9	-18.9	-17.2	-17.2	-15.4	-15.4	-14.6	-14.6	-14.1	-14.1	
	11.9	12.8	9.3	10.2	9.3	10.2	9.3	10.2	9.3	10.2	
200	-22.4	-22.4	-20.4	-20.4	-18.5	-18.5	-17.5	-17.5	-16.9	-16.9	
	13.9	15.2	10.8	12.2	10.8	12.2	10.8	12.2	10.8	12.2	
220	-25.9	-25.9	-23.7	-23.7	-21.5	-21.5	-20.4	-20.4	-19.7	-19.7	
	15.8	17.5	12.4	14.2	12.4	14.2	12.4	14.2	12.4	14.2	
240	-29.4	-29.4	-26.9	-26.9	-24.5	-24.5	-23.3	-23.3	-22.5	-22.5	
	17.7	19.9	13.9	16.2	13.9	16.2	13.9	16.2	13.9	16.2	
260	-32.9	-32.9	-30.2	-30.2	-27.5	-27.5	-26.2	-26.2	-25.4	-25.4	
	19.6	22.3	15.5	18.2	15.5	18.2	15.5	18.2	15.5	18.2	
280	-36.4	-36.4	-33.5	-33.5	-30.5	-30.5	-29.1	-29.1	-28.2	-28.2	
	21.5	24.6	17.0	20.2	17.0	20.2	17.0	20.2	17.0	20.2	
Element height [mm]	$V_{Rd,y}$ [kN]										
180–280	±16.2 ±18.2										

Load bearing capacity values for further types and for concrete strength C30/37 can be found in the type tests at www.halfen.com or on request.
→ See back cover for contact information.

HIT-SP SDV 2M20-0210	Section A-A $V_{Rd,A}$ [kN]		Section B-B for selected shear load $V_{Rd,B}$ [kN]								M20
	43.9 -15.4	43.9 -15.4	25.0 -15.4	25.0 -15.4	30.0 -15.4	30.0 -15.4	40.0 -15.4	40.0 -15.4	43.9 -15.4	43.9 -15.4	
Element height [mm]	$M_{Rd,A}$ [kNm]		$M_{Rd,B}$ [kNm]								
180	-18.9	-18.9	-14.6	-14.6	-13.7	-13.7	-12.0	-12.0	-11.3	-11.3	
	11.9	12.8	9.3	10.2	9.3	10.2	9.3	10.2	9.3	10.2	
200	-22.4	-22.4	-17.5	-17.5	-16.5	-16.5	-14.6	-14.6	-13.8	-13.8	
	13.9	15.2	10.8	12.2	10.8	12.2	10.8	12.2	10.8	12.2	
220	-25.9	-25.9	-20.4	-20.4	-19.3	-19.3	-17.1	-17.1	-16.2	-16.2	
	15.8	17.5	12.4	14.2	12.4	14.2	12.4	14.2	12.4	14.2	
240	-29.4	-29.4	-23.3	-23.3	-22.1	-22.1	-19.6	-19.6	-18.7	-18.7	
	17.7	19.9	13.9	16.2	13.9	16.2	13.9	16.2	13.9	16.2	
260	-32.9	-32.9	-26.2	-26.2	-24.9	-24.9	-22.2	-22.2	-21.1	-21.1	
	19.6	22.3	15.5	18.2	15.5	18.2	15.5	18.2	15.5	18.2	
280	-36.4	-36.4	-29.1	-29.1	-27.6	-27.6	-24.7	-24.7	-23.6	-23.6	
	21.5	24.6	17.0	20.2	17.0	20.2	17.0	20.2	17.0	20.2	
Element height [mm]	$V_{Rd,y}$ [kN]										
180–280	±18.2 ±20.3										

Load bearing capacity values for further types and for concrete strength C30/37 can be found in the type tests at www.halfen.com or on request.
→ See back cover for contact information.

1 SDV
2 SMV
3 SZV
4 CONSTRUCTION
5 BUILDING PHYSICS

Halfen HIT Steel to Concrete Connector

HIT-SP SDV

Resistance at ultimate load capacity



Shear capacity / Moment bearing capacity

Concrete strength: C20/25 ≥ C25/30



HIT-SP SDV 2M20-0212	Section A-A V _{Rd,A} [kN]		Section B-B for selected shear load V _{Rd,B} [kN]								M20 					
	Design values	63.2	63.2	40.0	40.0	50.0	50.0	60.0	60.0	63.2		63.2	-15.4	-15.4	-15.4	-15.4
Element height [mm]	M _{Rd,A} [kNm]		M _{Rd,B} [kNm]													
180	-18.9	-18.9	-12.0	-12.0	-10.3	-10.3	-8.6	-8.6	-8.0	-8.0	11.9	12.8	9.3	10.2	9.3	10.2
200	-22.4	-22.4	-14.6	-14.6	-12.6	-12.6	-10.6	-10.6	-10.0	-10.0	13.9	15.2	10.8	12.2	10.8	12.2
220	-25.9	-25.9	-17.1	-17.1	-14.9	-14.9	-12.7	-12.7	-12.0	-12.0	15.8	17.5	12.4	14.2	12.4	14.2
240	-29.4	-29.4	-19.6	-19.6	-17.2	-17.2	-14.8	-14.8	-14.0	-14.0	17.7	19.9	13.9	16.2	13.9	16.2
260	-32.9	-32.9	-22.2	-22.2	-19.5	-19.5	-16.8	-16.8	-16.0	-16.0	19.6	22.3	15.5	18.2	15.5	18.2
280	-36.4	-36.4	-24.7	-24.7	-21.8	-21.8	-18.9	-18.9	-18.0	-18.0	21.5	24.6	17.0	20.2	17.0	20.2
Element height [mm]	V _{Rd,y} [kN]															
180–280	±20.2 ±22.6															

Load bearing capacity values for further types and for concrete strength C30/37 can be found in the type tests at www.halfen.com or on request.
→ See back cover for contact information.

HIT-SP SDV 2M22-0208	Section A-A V _{Rd,A} [kN]		Section B-B for selected shear load V _{Rd,B} [kN]								M22 					
	Design values	28.1	28.1	10.0	10.0	20.0	20.0	25.0	25.0	28.1		28.1	-15.4	-15.4	-15.4	-15.4
Element height [mm]	M _{Rd,A} [kNm]		M _{Rd,B} [kNm]													
180	-27.4	-29.5	-25.7	-27.8	-24.0	-26.1	-23.1	-25.2	-22.6	-24.7	16.1	17.6	13.5	15.0	13.5	15.0
200	-32.5	-35.0	-30.5	-33.0	-28.6	-31.1	-27.6	-30.1	-27.0	-29.5	18.7	20.9	15.7	17.9	15.7	17.9
220	-37.0	-40.4	-34.8	-38.2	-32.7	-36.0	-31.6	-34.9	-30.9	-34.3	21.5	24.2	18.1	20.8	18.1	20.8
240	-41.4	-45.7	-38.9	-43.3	-36.5	-40.8	-35.3	-39.6	-34.5	-38.9	24.2	27.4	20.5	23.7	20.5	23.7
260	-45.6	-50.2	-42.9	-47.6	-40.2	-44.9	-38.9	-43.6	-38.1	-42.7	26.9	30.7	22.8	26.6	22.8	26.6
280	-49.6	-54.7	-46.7	-51.8	-43.8	-48.9	-42.4	-47.4	-41.5	-46.5	29.7	33.9	25.2	29.5	25.2	29.5
Element height [mm]	V _{Rd,y} [kN]															
180–280	±16.5 ±18.5															

Load bearing capacity values for further types and for concrete strength C30/37 can be found in the type tests at www.halfen.com or on request.
→ See back cover for contact information.

Halfen HIT Steel to Concrete Connector

HIT-SP SDV

Resistance at ultimate load capacity



Shear capacity / Moment bearing capacity

Concrete strength: C20/25 ≥ C25/30



HIT-SP SDV 2M22-0210	Section A-A V _{Rd,A} [kN]		Section B-B for selected shear load V _{Rd,B} [kN]						M22	
	43.9	43.9	25.0	25.0	30.0	30.0	40.0	40.0	43.9	43.9
Design values	-15.4	-15.4	-15.4	-15.4	-15.4	-15.4	-15.4	-15.4	-15.4	-15.4
Element height [mm]	M _{Rd,A} [kNm]		M _{Rd,B} [kNm]							
180	-27.4	-29.5	-23.1	-25.2	-22.3	-24.4	-20.5	-22.6	-19.9	-22.0
	16.1	17.6	13.5	15.0	13.5	15.0	13.5	15.0	13.5	15.0
200	-32.5	-35.0	-27.6	-30.1	-26.6	-29.1	-24.7	-27.1	-23.9	-26.4
	18.7	20.9	15.7	17.9	15.7	17.9	15.7	17.9	15.7	17.9
220	-37.0	-40.4	-31.6	-34.9	-30.5	-33.9	-28.3	-31.7	-27.4	-30.8
	21.5	24.2	18.1	20.8	18.1	20.8	18.1	20.8	18.1	20.8
240	-41.4	-45.7	-35.3	-39.6	-34.1	-38.4	-31.6	-36.0	-30.7	-35.0
	24.2	27.4	20.5	23.7	20.5	23.7	20.5	23.7	20.5	23.7
260	-45.6	-50.2	-38.9	-43.6	-37.6	-42.2	-34.9	-39.6	-33.9	-38.5
	26.9	30.7	22.8	26.6	22.8	26.6	22.8	26.6	22.8	26.6
280	-49.6	-54.7	-42.4	-47.4	-40.9	-46.0	-38.0	-43.1	-36.9	-41.9
	29.7	33.9	25.2	29.5	25.2	29.5	25.2	29.5	25.2	29.5
Element height [mm]	V _{Rd,y} [kN]									
180–280	±18.5					±20.7				

Load bearing capacity values for further types and for concrete strength C30/37 can be found in the type tests at www.halfen.com or on request.
→ See back cover for contact information.

HIT-SP SDV 2M22-0212	Section A-A V _{Rd,A} [kN]		Section B-B for selected shear load V _{Rd,B} [kN]						M22	
	63.2	63.2	40.0	40.0	50.0	50.0	60.0	60.0	63.2	63.2
Design values	-15.4	-15.4	-15.4	-15.4	-15.4	-15.4	-15.4	-15.4	-15.4	-15.4
Element height [mm]	M _{Rd,A} [kNm]		M _{Rd,B} [kNm]							
180	-27.4	-29.5	-20.5	-22.6	-18.8	-20.9	-17.1	-19.2	-16.6	-18.7
	16.1	17.6	13.5	15.0	13.5	15.0	13.5	15.0	13.5	15.0
200	-32.5	-35.0	-24.7	-27.1	-22.7	-25.2	-20.7	-23.2	-20.1	-22.6
	18.7	20.9	15.7	17.9	15.7	17.9	15.7	17.9	15.7	17.9
220	-37.0	-40.4	-28.3	-31.7	-26.1	-29.5	-23.9	-27.3	-23.2	-26.6
	21.5	24.2	18.1	20.8	18.1	20.8	18.1	20.8	18.1	20.8
240	-41.4	-45.7	-31.6	-36.0	-29.2	-33.5	-26.8	-31.1	-26.0	-30.3
	24.2	27.4	20.5	23.7	20.5	23.7	20.5	23.7	20.5	23.7
260	-45.6	-50.2	-34.9	-39.6	-32.2	-36.9	-29.6	-34.2	-28.7	-33.4
	26.9	30.7	22.8	26.6	22.8	26.6	22.8	26.6	22.8	26.6
280	-49.6	-54.7	-38.0	-43.1	-35.1	-40.1	-32.2	-37.2	-31.3	-36.3
	29.7	33.9	25.2	29.5	25.2	29.5	25.2	29.5	25.2	29.5
Element height [mm]	V _{Rd,y} [kN]									
180–280	±20.5					±23.0				

Load bearing capacity values for further types and for concrete strength C30/37 can be found in the type tests at www.halfen.com or on request.
→ See back cover for contact information.

Halfen HIT Steel to Concrete Connector

HIT-HP SDV, HIT-SP SDV

Product specifications HIT-HP/SP SDV-2M12 and -2M16

HIT-HP/SP SDV-2M12 with installation aid
Section

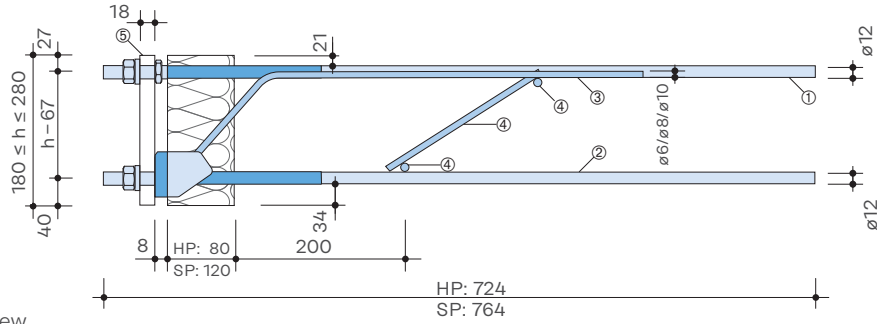

- ① Tension bar
- ② Compression bar
- ③ Shear bar
- ④ Constructive installation rebar
- ⑤ Installation aid

Plan view

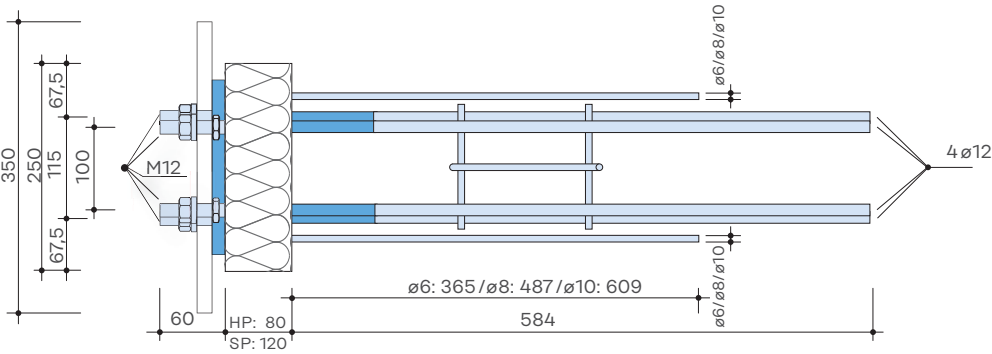

Dimensions in [mm]

HIT-HP/SP SDV-2M16 with installation aid
Section

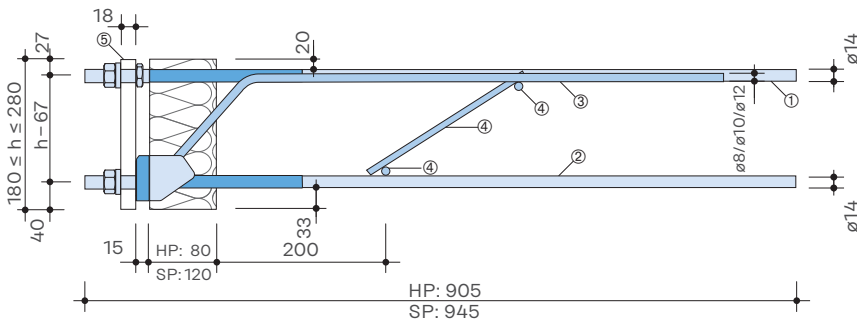

- ① Tension bar
- ② Compression bar
- ③ Shear bar
- ④ Constructive installation rebar
- ⑤ Installation aid

Plan view

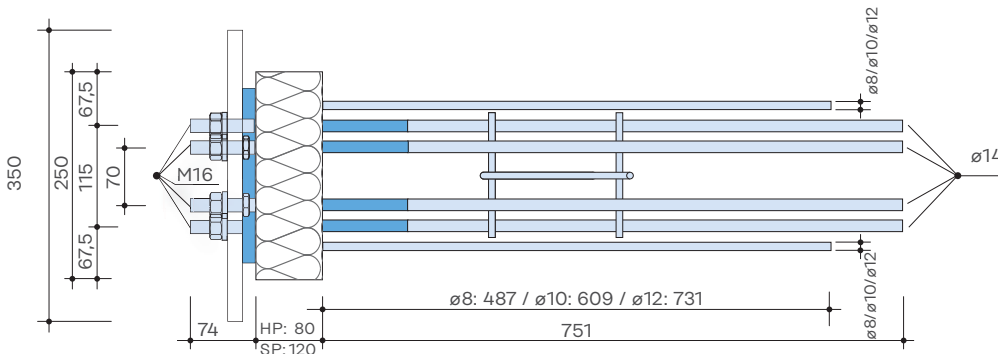

Dimensions in [mm]

SDV 1

SMV 2

SZV 3

CONSTRUCTION 4

BUILDING PHYSICS 5

Halfen HIT Steel to Concrete Connector

HIT-HP SDV, HIT-SP SDV

Product specifications HIT-HP/SP SDV-2M20 and -2M22

HIT-HP/SP SDV-2M20 with installation aid

Section

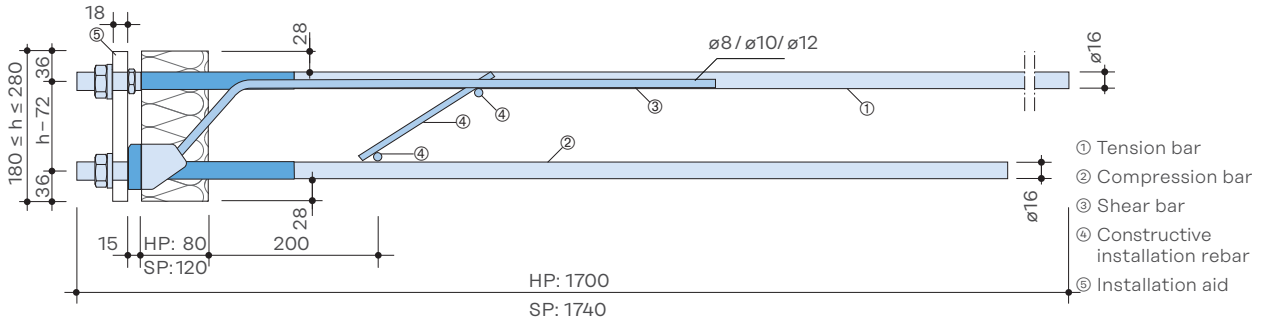

Plan view

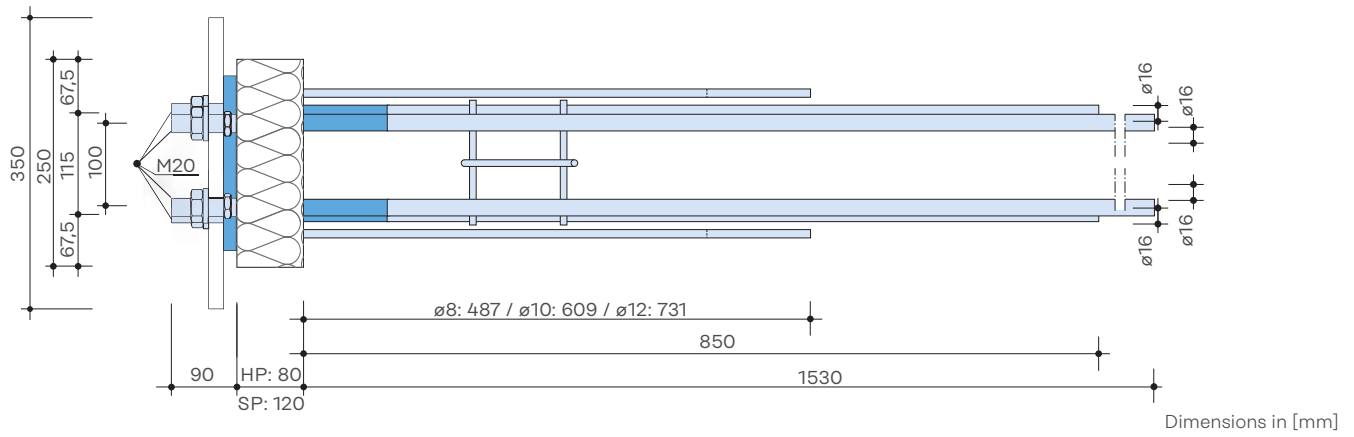

HIT-HP/SP SDV-2M22 with installation aid

Section

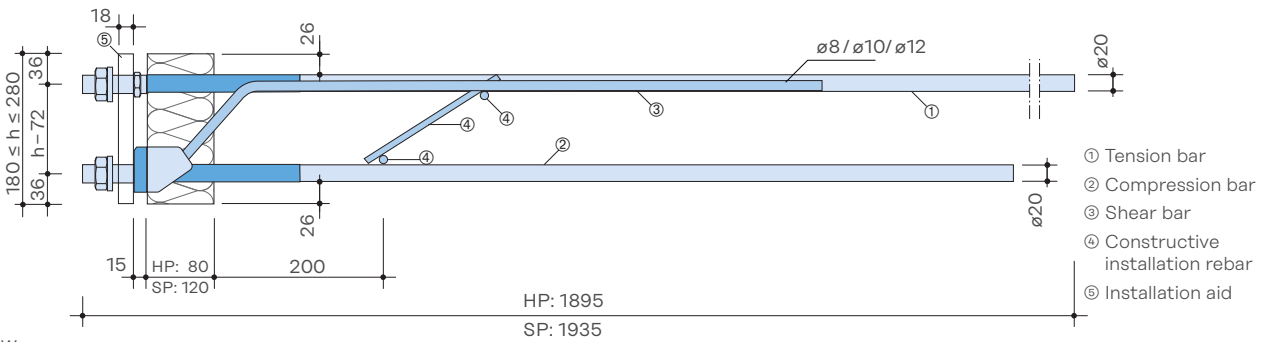

Plan view

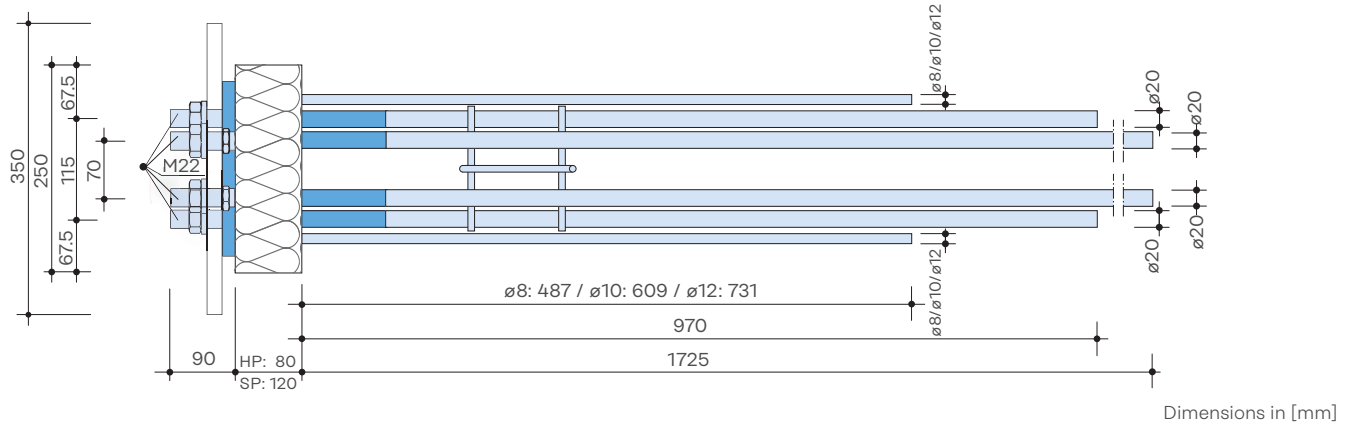

Halfen HIT Steel to Concrete Connector

HIT-HP SDV, HIT-SP SDV

SDV

1

On-site reinforcement HIT-HP/SP SDV-2M12 / -2M16 / -2M-20

Section

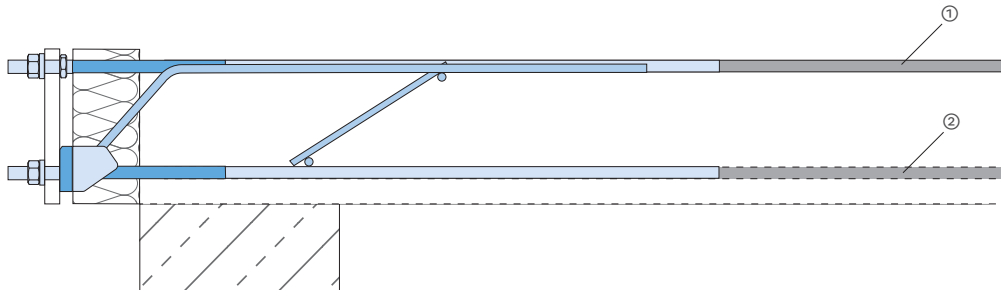

SMV

2

Plan view

Figure: Overlap with on-site reinforcement

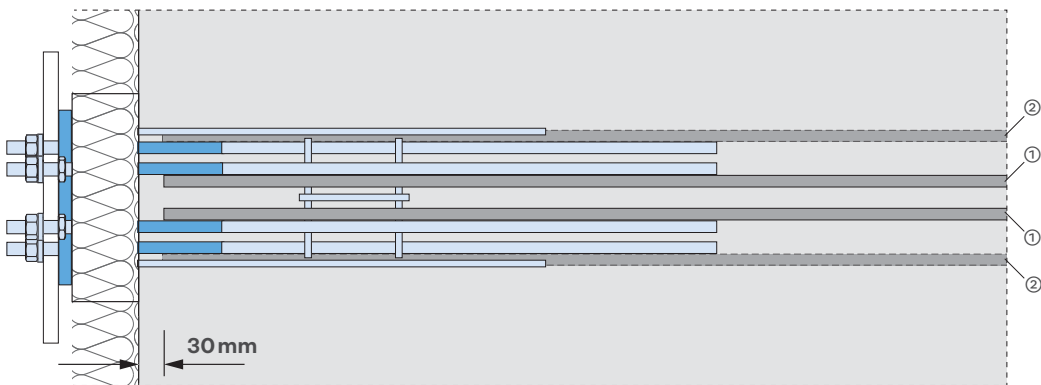

SZV

3

CONSTRUCTION

4

Position ①: for HIT-SDV 2M12 - 2 ϕ 12mm
 for HIT-SDV 2M16 - 2 ϕ 14mm
 for HIT-SDV 2M20 - 2 ϕ 16mm
 For connection reinforcement, diameter same as reinforcing steel of HIT elements.
 The length of the bars is derived from the tension bar overlap according to the structural design plans.

Position ②: Only required for lifting moments.
 for HIT-SDV 2M12 - 2 ϕ 12mm
 for HIT-SDV 2M16 - 2 ϕ 14mm
 for HIT-SDV 2M20 - 2 ϕ 16mm
 For connection reinforcement, diameter same as reinforcing steel of HIT elements.
 The length of the bars is derived from the tension bar overlap according to the structural design plans.

BUILDING PHYSICS

5



On-site reinforcement according to the structural engineer's specifications.



Constructive reinforcement for the free slab edge in accordance with EN 1992-1-1

Halfen HIT Steel to Concrete Connector

HIT-HP SDV, HIT-SP SDV

On-site reinforcement HIT-HP/SP SDV-2M22

Section

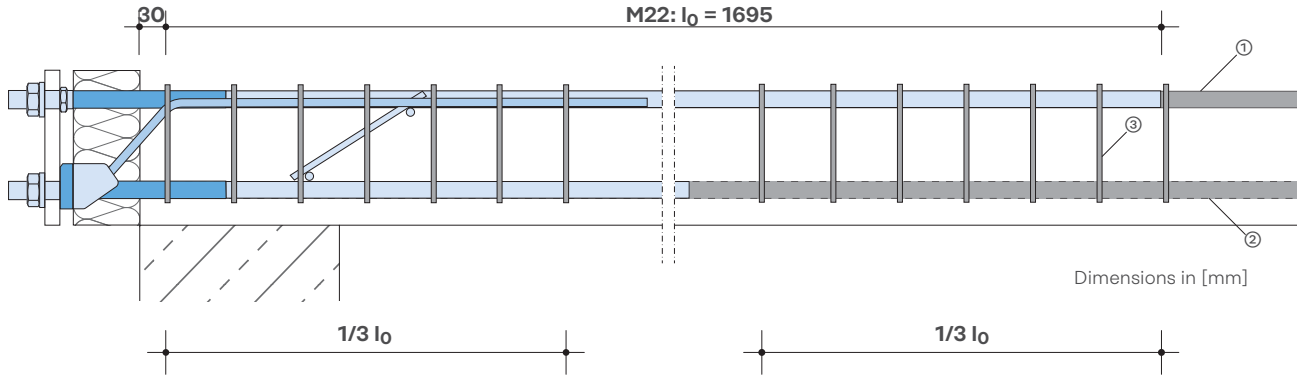

Plan view

Figure: Overlap length with on-site reinforcement

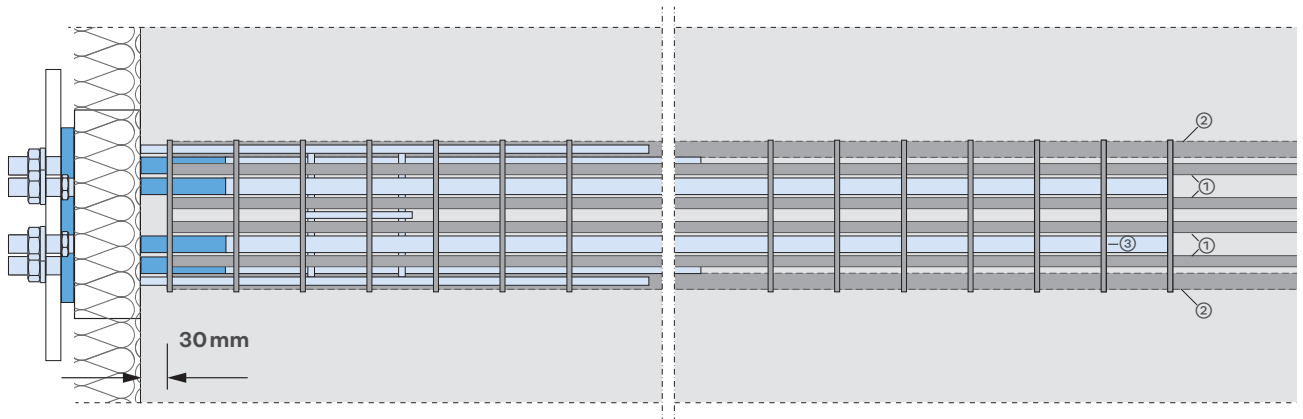

Position ①: $\geq 4\phi 14$; The length of the bars is derived from the tension bar overlap according to the structural design plans.

Position ②: $\geq 4\phi 14$; Only required for lifting moments.

Number, diameter and length of the bars according to the structural design plans.

Position ③: Stirrups $\geq 14\phi 6$; spacing $s = 80$ mm

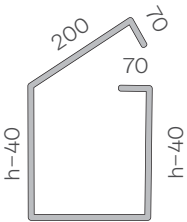

200
Dimensions, stirrups
(14 at $\phi 6$ mm)
Dimensions in [mm]



Stirrup layout according to EN 1992-1-1; 8, 7, 4, 2



Constructive reinforcement for the free slab edge in accordance with EN 1992-1-1

1 SDV

2 SMV

3 SZV

4 CONSTRUCTION

5 BUILDING PHYSICS

Halfen HIT Steel to Concrete Connector

HIT-HP SDV, HIT-SP SDV

SDV

1 For the HIT-HP/SP SDV elements, the torsional deformations resulting from elastic formwork deformation in the insulation/load inducement joint area α_M are assumed due to a standard effective moment of $M_{Ed} = 1 \text{ kNm}$.

The required camber to compensate for elastic deformation of the connected steel structure can be approximated as follows:

$$\ddot{u} = \alpha_M \cdot l_k \cdot M_{Ed}$$

- 2** with \ddot{u} = Camber [mm]
 α_M = Torque resulting from $M_{Ed} = 1 \text{ kNm}$;
 Table values in [%/kNm]
 l_k = Span distance, cantilever beam [m]
 M_{Ed} = Design value of the effective moments [kNm]
 at serviceability limit state (SLS)

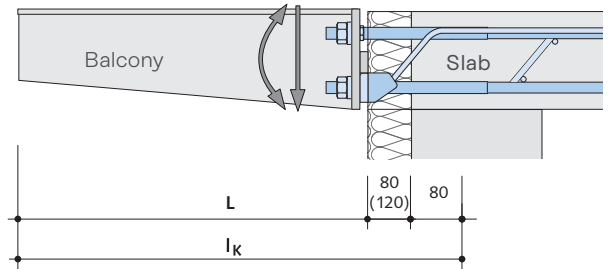

L = Cantilever length [m]

l_k = Span distance, cantilever beam [m]

SMV

SVZ

3

Other deformation factors resulting from deformation of the connected steel structure must be considered by the structural engineer when determining the overall camber. The α_M values [%/kNm] in the following table are in accordance with approval no. Z-15.7-336.

CONSTRUCTION

4

HIT-HP SDV				
Element height h [mm]	HP SDV-2M12	HP SDV-2M16	HP SDV-2M20	HP SDV-2M22
180	1.310	0.845	0.683	0.551
200	0.946	0.610	0.487	0.392
220	0.715	0.461	0.364	0.294
240	0.559	0.360	0.282	0.228
260	0.449	0.290	0.226	0.182
280	0.369	0.238	0.184	0.149

BUILDING PHYSICS

5

HIT-SP SDV				
Element height h [mm]	SP SDV-2M12	SP SDV-2M16	SP SDV-2M20	SP SDV-2M22
180	1.509	0.953	0.759	0.613
200	1.089	0.688	0.541	0.437
220	0.823	0.520	0.404	0.327
240	0.644	0.407	0.314	0.253
260	0.517	0.327	0.251	0.202
280	0.425	0.268	0.205	0.165

Halfen HIT Steel to Concrete Connector

HIT-HP SDV, HIT-SP SDV

Torsion spring stiffnesses

HIT-HP SDV				
Torsion spring C [kNm/rad] for Element height h [mm]	HP SDV-2M12	HP SDV-2M16	HP SDV-2M20	HP SDV-2M22
180	763	1184	1464	1814
200	1057	1640	2053	2548
220	1399	2170	2747	3406
240	1789	2775	3546	4389
260	2227	3454	4425	5497
280	2710	4207	5435	6728

HIT-SP SDV				
Torsion spring C [kNm/rad] for Element height h [mm]	SP SDV-2M12	SP SDV-2M16	SP SDV-2M20	SP SDV-2M22
180	663	1049	1318	1631
200	918	1453	1848	2291
220	1215	1923	2475	3063
240	1553	2459	3185	3946
260	1934	3060	3984	4942
280	2353	3728	4878	6049

1 SDV

2 SMV

3 SZV

4 CONSTRUCTION

5 BUILDING PHYSICS

Halfen HIT Steel to Concrete Connector

HIT-HP SDV, HIT-SP SDV

SDV 1

Axial spacing

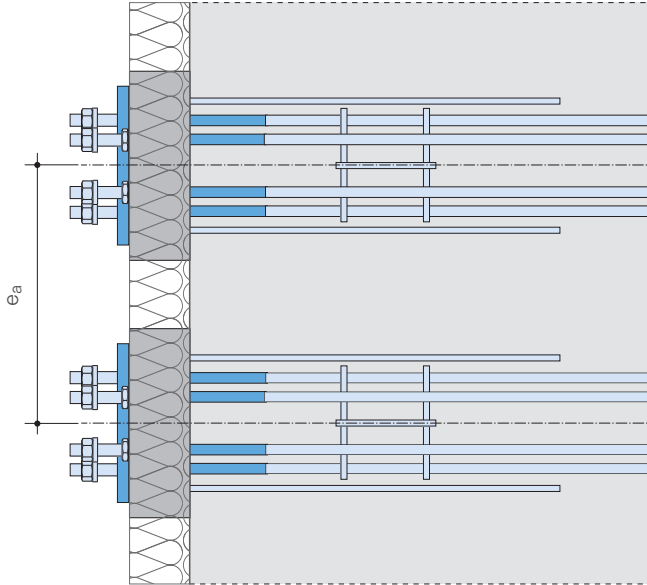

HIT Type	Axial spacing $e_a \geq$ [mm]
HIT-HP SDV	250*
HIT-SP SDV	250*

*Custom elements with smaller spacings on request

SMV 2

SZV 3

Edge distance

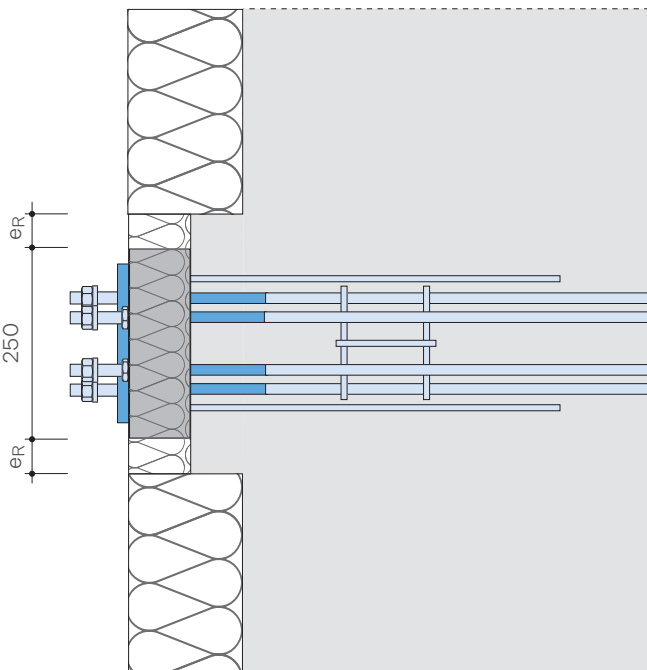

HIT-Type	Distance e_R [mm]
HIT-HP/SP SDV-2M12-0206	0
HIT-HP/SP SDV-2M12-0208	13
HIT-HP/SP SDV-2M12-0210	22
HIT-HP/SP SDV-2M16-0208	13
HIT-HP/SP SDV-2M16-0210	22
HIT-HP/SP SDV-2M16-0212	33
HIT-HP/SP SDV-2M20-0208	13
HIT-HP/SP SDV-2M20-0210	22
HIT-HP/SP SDV-2M20-0212	33
HIT-HP/SP SDV-2M22-0208	13
HIT-HP/SP SDV-2M22-0210	22
HIT-HP/SP SDV-2M22-0212	33

KONSTRUKTION 4

BAUPHYSIK 5

Halfen HIT Steel to Concrete Connector

HIT-HP SDV, HIT-SP SDV

Distance from an outer corner

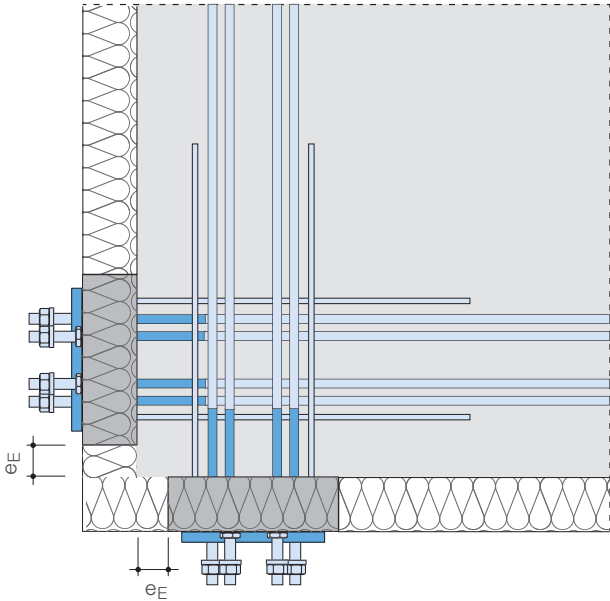

HIT Type	Distance e_E [mm]
HIT-HP/SP SDV-2M12-0206	0
HIT-HP/SP SDV-2M12-0208	13
HIT-HP/SP SDV-2M12-0210	22
HIT-HP/SP SDV-2M16-0208	13
HIT-HP/SP SDV-2M16-0210	22
HIT-HP/SP SDV-2M16-0212	33
HIT-HP/SP SDV-2M20-0208	13
HIT-HP/SP SDV-2M20-0210	22
HIT-HP/SP SDV-2M20-0212	33
HIT-HP/SP SDV-2M22-0208	13
HIT-HP/SP SDV-2M22-0210	22
HIT-HP/SP SDV-2M22-0212	33

Height-offset for an outer corner

To install the HIT-SDV elements at an external corner, it is necessary to offset the installation height of the elements. The required height offset is achieved using 20mm insulation strips (not included).

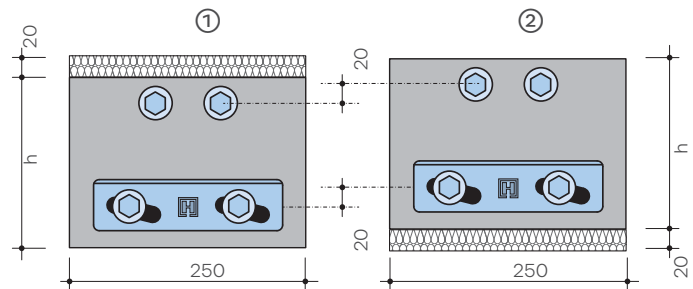
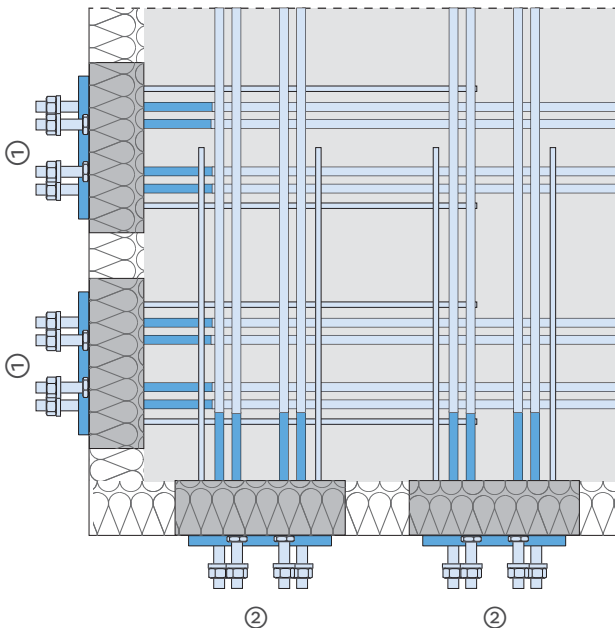

HIT-SDV 2M22: No tolerances are considered in the 20mm height offset. We therefore recommend an offset of 25mm for these types.

Halfen HIT Steel to Concrete Connector

HIT-HP SDV, HIT-SP SDV

Installation instructions concrete

SDV 1

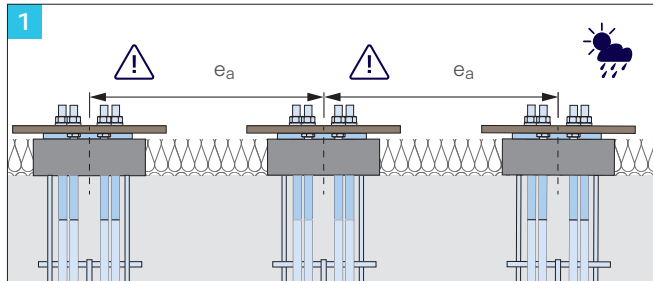

1 Installing the bottom reinforcement layer (example, mesh reinforcement).
Installing the HIT Element from above.

! Install the HIT Element with increased accuracy as the steel construction is post-installed!

SMV 2

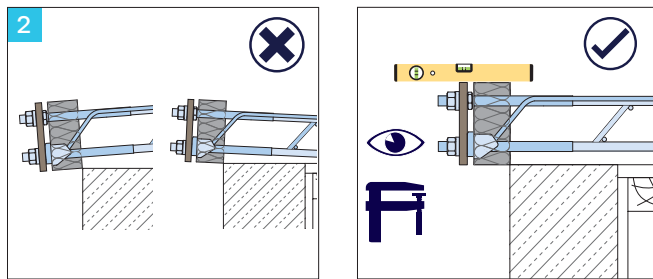

2 Accurate installation

! Ensure installation is exactly horizontal and vertical!

! Ensure the formwork is installed at the correct height!

SZV 3

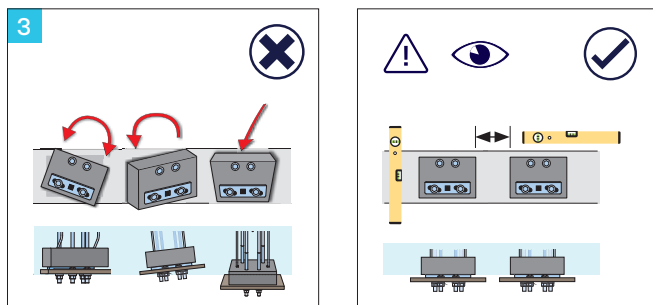

3 Checking horizontal and vertical alignment

The included (wood) installation aids are used to precisely align the elements; the overhanging edges can be used to fix to the on-site formwork as required.

Alternative: Make installation aids on-site (for example, in wood or U-profiles). Use the supplied installation aids or alternatively our drilling templates to transfer the drill hole sizes and element distances to the on-site made installation aids.

CONSTRUCTION 4

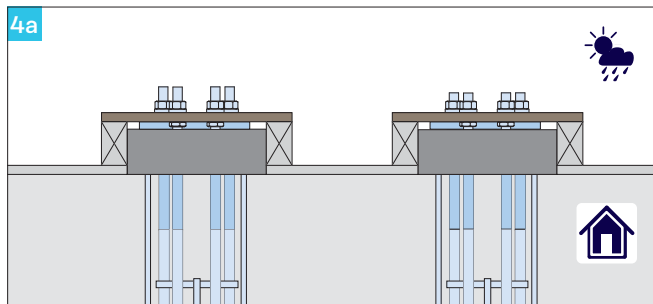

4 Installing the formwork

a Concreting directly against the formwork

BUILDING PHYSICS 5

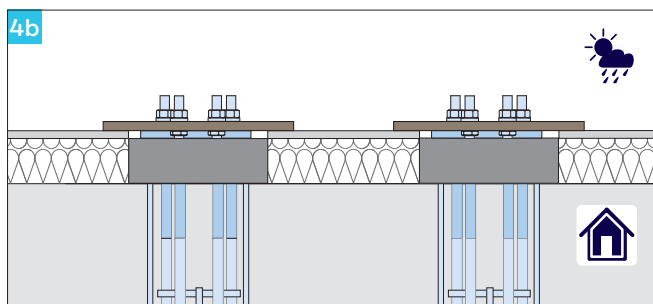

b Concreting directly against the insulation

! A free drilling template (.pdf file) is available at:
 ▶ www.halfen.com ▶ Product Ranges ▶ Construction
 ▶ Reinforcement systems ▶ HIT Steel to Concrete Connector
 ▶ Product Information ▶ Installation Instructions

Halfen HIT Steel to Concrete Connector

HIT-HP SDV, HIT-SP SDV

Installation in concrete

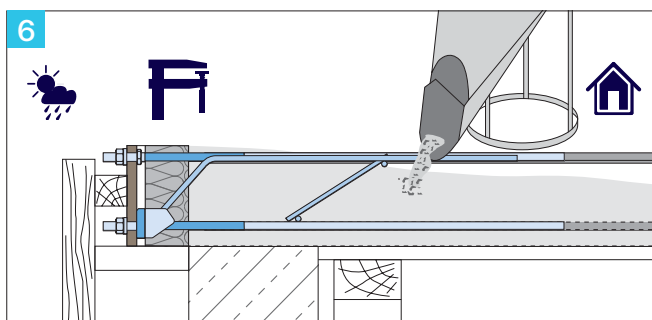
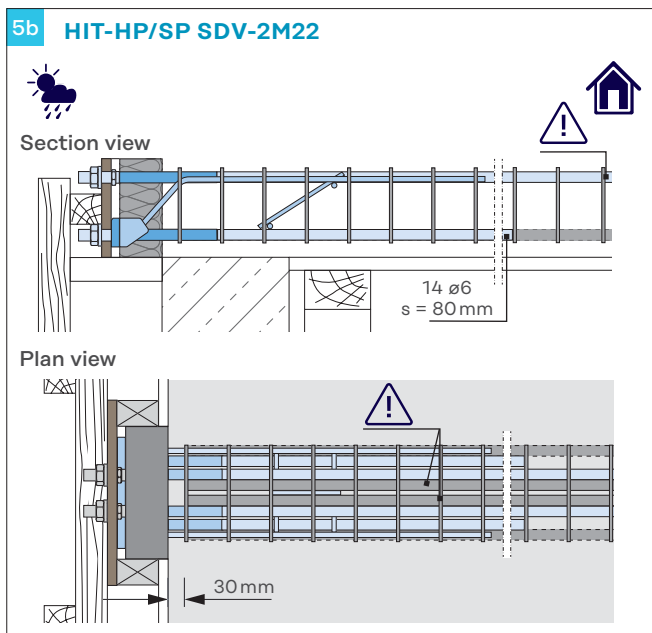
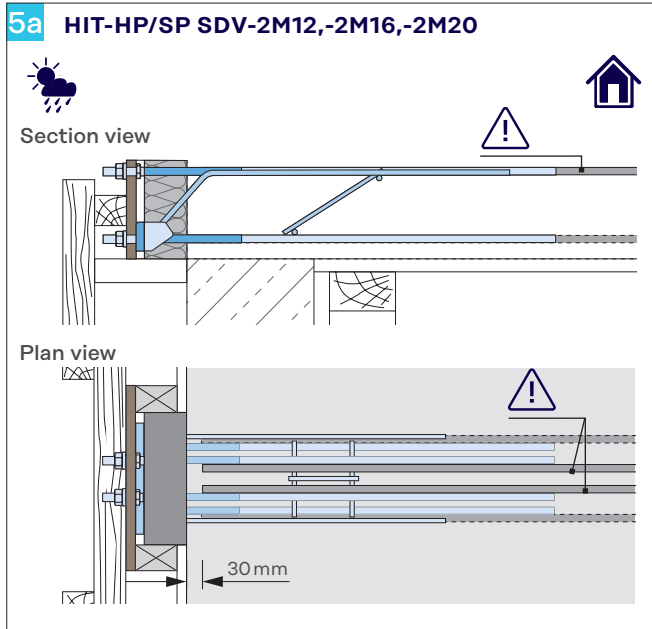

5 Installing the on-site reinforcement

a Installing the on-site reinforcement for HIT-HP/SP SDV-2M12, -2M16, -2M20

On-site reinforcement must be placed as specified by the structural engineer.

Structural reinforcement of the slab free edge according to EN 1992-1-1

b Installing the on-site reinforcement for HIT-HP/SP SDV-2M22

On-site reinforcement must be placed as specified by the structural engineer.

Structural reinforcement of the slab free edge according to EN 1992-1-1

Stirrup layout in accordance with EN 1992-1-1; 8.7.4.2

6 Pouring the concrete

To ensure the HIT units are not displaced, ensure the concrete is poured and compacted evenly.

1 SDV

2 SMV

3 SZV

4 KONSTRUKTION

5 BAUPHYSIK

Halfen HIT Steel to Concrete Connector

HIT-HP SMV, HIT-SP SMV

SDV 1

2

- Element for connecting steel constructions to reinforced concrete structures
- Transfer of negative bending moments and positive shear loads as well as horizontal forces parallel to the joint



SMV 2



SZV 3

CONSTRUCTION 4

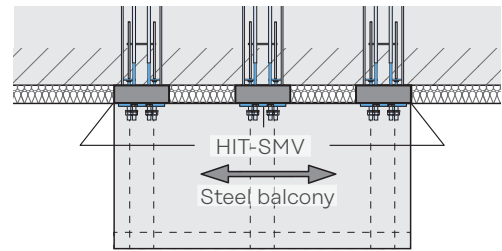
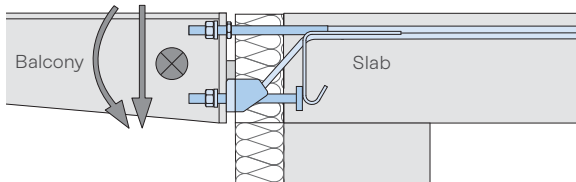

HIT-HP SMV – High Performance with 80 mm insulation
 HIT-SP SMV – Superior Performance with 120 mm insulation

Application: Cantilever balcony

BUILDING PHYSICS 5

Contents	Type	Page
Load range	HIT-HP SMV, HIT-SP SMV	45
Load capacity values	HIT-HP SMV, HIT-SP SMV	46
Product description	HIT-HP SMV, HIT-SP SMV	52
On-site connecting reinforcement	HIT-HP SMV, HIT-SP SMV	53
Deformation	HIT-HP SMV, HIT-SP SMV	54
Torsion spring stiffnesses	HIT-HP SMV, HIT-SP SMV	55
Axial spacings	HIT-HP SMV, HIT-SP SMV	56
Installation instructions	HIT-HP SMV, HIT-SP SMV	58

Halfen HIT Steel to Concrete Connector

HIT-HP SMV, HIT-SP SMV

Load capacity range

Combinations of two moments and four shear load ranges are available.
The following combinations of tension bars, anchor head compression bars and shear load bars are available for HIT-HP 80 mm and HIT-SP 120 mm insulation thickness.

Element width B = 25 cm					
Number and diameter of the connection bolts; balcony side	Number and diameter of the tension bars; main slab	Number and diameter of the shear load bars			
		2 ø6	2 ø8	2 ø10	2 ø12
2M12	2ø12	●	●	●	
2M16	2ø14		●	●	●

→ See the following pages for load capacity values for selected elements ● = HP and SP

Basic types – Ordering example

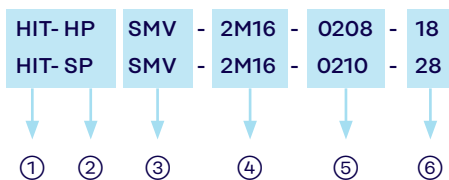

Type designation

- ① Product group
- ② Joint spacing 80 mm (HP) or 120 mm (SP)
- ③ Connection type
- ④ Moment load range
- ⑤ Shear load range
- ⑥ Element height [cm]



Custom Solutions

Halfen HIT Insulated connections

Our technical support team is available if a custom solution is required for your project.

Contact details: → see back cover of catalogue

Technical data

Element description HIT-HP/HIT-SP	Possible element height h [mm]	Balcony side	Main slab side				min. concrete cover Main slab side [mm]	
		Thread	Tension bar [mm]	Compression bar	Shear load bars [mm]	Stirrups [mm]	C _{v,top}	C _{v,bottom}
SMV-2M12-0206	180–280	2M12	2 ø12	Anchor head	2 ø6	2 ø8	21	34
SMV-2M12-0208		2M12	2 ø12	Anchor head	2 ø8	2 ø8	21	34
SMV-2M12-0210		2M12	2 ø12	Anchor head	2 ø10	2 ø8	21	34
SMV-2M16-0208		2M16	2 ø14	Anchor head	2 ø8	2 ø8	20	33
SMV-2M16-0210		2M16	2 ø14	Anchor head	2 ø10	2 ø8	20	33
SMV-2M16-0212		2M16	2 ø14	Anchor head	2 ø12	2 ø8	20	33

Halfen HIT Steel to Concrete Connector

HIT-HP SMV

Resistance at ultimate load capacity



Shear capacity / Moment bearing capacity

Concrete strength: C20/25 ≥ C25/30



HIT-HP SMV 2M12-0206	Section A-A $V_{Rd,A}$ [kN]		Section B-B for selected shear load $V_{Rd,B}$ [kN]						M12	
	Design values	18.8	18.8	5.0	5.0	10.0	10.0	15.0	15.0	18.8
Element height [mm]	$M_{Rd,A}$ [kNm]		$M_{Rd,B}$ [kNm]							
180	-7.6	-9.5	-6.9	-8.8	-6.3	-8.2	-5.6	-7.5	-5.1	-7.0
200	-9.0	-11.2	-8.2	-10.4	-7.5	-9.7	-6.7	-9.0	-6.1	-8.4
220	-10.3	-12.9	-9.5	-12.0	-8.6	-11.2	-7.8	-10.4	-7.2	-9.7
240	-11.6	-14.6	-10.7	-13.6	-9.8	-12.7	-8.9	-11.8	-8.2	-11.1
260	-13.0	-16.2	-12.0	-15.2	-11.0	-14.2	-10.0	-13.2	-9.2	-12.5
280	-14.3	-17.9	-13.3	-16.8	-12.2	-15.8	-11.1	-14.7	-10.3	-13.8
Element height [mm]	$V_{Rd,y}$ [kN]									
180–280	±11.4					±12.7				

Load bearing capacity values for further types and for concrete strength C30/37 can be found in the type tests at www.halfen.com or on request.
→ See back cover for contact information.

HIT-HP SMV 2M12-0208	Section A-A $V_{Rd,A}$ [kN]		Section B-B for selected shear load $V_{Rd,B}$ [kN]						M12	
	Design values	33.5	33.5	10.0	10.0	20.0	20.0	30.0	30.0	33.5
Element height [mm]	$M_{Rd,A}$ [kNm]		$M_{Rd,B}$ [kNm]							
180	-7.6	-9.5	-6.3	-8.2	-5.0	-6.9	-3.6	-5.5	-3.2	-5.1
200	-9.0	-11.2	-7.5	-9.7	-6.0	-8.2	-4.5	-6.7	-4.0	-6.2
220	-10.3	-12.9	-8.6	-11.2	-7.0	-9.6	-5.3	-7.9	-4.7	-7.3
240	-11.6	-14.6	-9.8	-12.7	-8.0	-10.9	-6.2	-9.1	-5.5	-8.4
260	-13.0	-16.2	-11.0	-14.2	-9.0	-12.3	-7.0	-10.3	-6.3	-9.6
280	-14.3	-17.9	-12.2	-15.8	-10.0	-13.6	-7.9	-11.4	-7.1	-10.7
Element height [mm]	$V_{Rd,y}$ [kN]									
180–280	±13.0					±14.5				

Load bearing capacity values for further types and for concrete strength C30/37 can be found in the type tests at www.halfen.com or on request.
→ See back cover for contact information.

Halfen HIT Steel to Concrete Connector

HIT-HP SMV

Resistance at ultimate load capacity



Shear capacity / Moment bearing capacity

Concrete strength: C20/25 ≥ C25/30



HIT-HP SMV 2M12-0210	Section A-A V _{Rd,A} [kN]		Section B-B for selected shear load V _{Rd,B} [kN]						M12	
Design values	52.3	52.3	30.0	30.0	40.0	40.0	50.0	50.0	52.3	52.3
Element height [mm]	M _{Rd,A} [kNm]		M _{Rd,B} [kNm]							
180	-7.6	-9.5	-3.6	-5.5	-2.3	-4.2	-1.0	-2.9	-0.7	-2.6
200	-9.0	-11.2	-4.5	-6.7	-3.0	-5.2	-1.5	-3.7	-1.1	-3.4
220	-10.3	-12.9	-5.3	-7.9	-3.7	-6.2	-2.0	-4.6	-1.6	-4.2
240	-11.6	-14.6	-6.2	-9.1	-4.3	-7.2	-2.5	-5.4	-2.1	-5.0
260	-13.0	-16.2	-7.0	-10.3	-5.0	-8.3	-3.0	-6.3	-2.6	-5.8
280	-14.3	-17.9	-7.9	-11.4	-5.7	-9.3	-3.5	-7.1	-3.0	-6.6
Element height [mm]	V _{Rd,y} [kN]									
180–280	±14.7					±16.4				

Load bearing capacity values for further types and for concrete strength C30/37 can be found in the type tests at www.halfen.com or on request.
→ See back cover for contact information.

HIT-HP SMV 2M16-0208	Section A-A V _{Rd,A} [kN]		Section B-B for selected shear load V _{Rd,B} [kN]						M16	
Design values	33.5	33.5	10.0	10.0	20.0	20.0	30.0	30.0	33.5	33.5
Element height [mm]	M _{Rd,A} [kNm]		M _{Rd,B} [kNm]							
180	-13.6	-15.1	-12.2	-13.7	-10.8	-12.3	-9.4	-10.9	-9.0	-10.5
200	-16.0	-17.8	-14.4	-16.2	-12.8	-14.7	-11.3	-13.1	-10.7	-12.6
220	-18.1	-20.5	-16.3	-18.8	-14.6	-17.0	-12.9	-15.3	-12.3	-14.7
240	-20.2	-23.2	-18.3	-21.3	-16.4	-19.4	-14.5	-17.5	-13.8	-16.8
260	-22.3	-25.8	-20.2	-23.8	-18.1	-21.7	-16.1	-19.6	-15.3	-18.9
280	-24.4	-28.4	-22.1	-26.2	-19.9	-24.0	-17.7	-21.7	-16.9	-21.0
Element height [mm]	V _{Rd,y} [kN]									
180–280	±15.4					±17.2				

Load bearing capacity values for further types and for concrete strength C30/37 can be found in the type tests at www.halfen.com or on request.
→ See back cover for contact information.



The verification can be performed either in section A-A or in section B-B.

1 SDV
2 SMV
3 SZV
4 CONSTRUCTION
5 BUILDING PHYSICS

Halfen HIT Steel to Concrete Connector

HIT-HP SMV

Resistance at ultimate load capacity



Shear capacity / Moment bearing capacity

Concrete strength: C20/25 ≥ C25/30



HIT-HP SMV 2M16-0210	Section A-A V _{Rd,A} [kN]		Section B-B for selected shear load V _{Rd,B} [kN]								M16
	52.3	52.3	30.0	30.0	40.0	40.0	50.0	50.0	52.3	52.3	
Design values											
Element height [mm]	M _{Rd,A} [kNm]		M _{Rd,B} [kNm]								
180	-13.6	-15.1	-9.4	-10.9	-8.1	-9.6	-6.7	-8.2	-6.3	-7.8	
200	-16.0	-17.8	-11.3	-13.1	-9.7	-11.6	-8.1	-10.0	-7.8	-9.6	
220	-18.1	-20.5	-12.9	-15.3	-11.1	-13.6	-9.4	-11.8	-9.0	-11.4	
240	-20.2	-23.2	-14.5	-17.5	-12.6	-15.6	-10.7	-13.7	-10.2	-13.2	
260	-22.3	-25.8	-16.1	-19.6	-14.0	-17.6	-11.9	-15.5	-11.5	-15.0	
280	-24.4	-28.4	-17.7	-21.7	-15.4	-19.5	-13.2	-17.3	-12.7	-16.8	
Element height [mm]	V _{Rd,y} [kN]										
180–280	±15.4					±17.2					

Load bearing capacity values for further types and for concrete strength C30/37 can be found in the type tests at www.halfen.com or on request.
→ See back cover for contact information.

HIT-HP SMV 2M16-0212	Section A-A V _{Rd,A} [kN]		Section B-B for selected shear load V _{Rd,B} [kN]								M16
	75.3	75.3	50.0	30.0	60.0	40.0	70.0	50.0	75.3	75.3	
Design values											
Element height [mm]	M _{Rd,A} [kNm]		M _{Rd,B} [kNm]								
180	-13.6	-15.1	-6.7	-8.2	-5.3	-6.8	-3.9	-5.4	-3.1	-4.6	
200	-16.0	-17.8	-8.1	-10.0	-6.6	-8.4	-5.0	-6.9	-4.2	-6.0	
220	-18.1	-20.5	-9.4	-11.8	-7.7	-10.1	-5.9	-8.4	-5.0	-7.5	
240	-20.2	-23.2	-10.7	-13.7	-8.8	-11.8	-6.9	-9.9	-5.9	-8.9	
260	-22.3	-25.8	-11.9	-15.5	-9.9	-13.4	-7.8	-11.4	-6.7	-10.3	
280	-24.4	-28.4	-13.2	-17.3	-11.0	-15.0	-8.7	-12.8	-7.5	-11.6	
Element height [mm]	V _{Rd,y} [kN]										
180–280	±16.4					±18.3					

Load bearing capacity values for further types and for concrete strength C30/37 can be found in the type tests at www.halfen.com or on request.
→ See back cover for contact information.

Halfen HIT Steel to Concrete Connector

HIT-SP SMV

Resistance at ultimate load capacity



Shear capacity / Moment bearing capacity

Concrete strength: C20/25 ≥ C25/30



HIT-SP SMV 2M12-0206	Section A-A V _{Rd,A} [kN]		Section B-B for selected shear load V _{Rd,B} [kN]						M12	
	15.8	15.8	5.0	5.0	10.0	10.0	15.0	15.0	15.8	15.8
Design values	15.8	15.8	5.0	5.0	10.0	10.0	15.0	15.0	15.8	15.8
Element height [mm]	M _{Rd,A} [kNm]		M _{Rd,B} [kNm]							
180	-7.6	-9.5	-6.7	-8.6	-5.9	-7.8	-5.0	-6.9	-4.8	-6.7
200	-9.0	-11.2	-8.0	-10.2	-7.0	-9.2	-6.0	-8.2	-5.8	-8.0
220	-10.3	-12.9	-9.2	-11.8	-8.1	-10.6	-7.0	-9.5	-6.8	-9.3
240	-11.6	-14.6	-10.4	-13.3	-9.2	-12.1	-7.9	-10.9	-7.7	-10.7
260	-13.0	-16.2	-11.6	-14.9	-10.3	-13.5	-8.9	-12.2	-8.7	-12.0
280	-14.3	-17.9	-12.9	-16.5	-11.4	-15.0	-9.9	-13.5	-9.7	-13.3
Element height [mm]	V _{Rd,y} [kN]									
180–280	±11.4 ±12.7									

Load bearing capacity values for further types and for concrete strength C30/37 can be found in the type tests at www.halfen.com or on request.
→ See back cover for contact information.

HIT-SP SMV 2M12-0208	Section A-A V _{Rd,A} [kN]		Section B-B for selected shear load V _{Rd,B} [kN]						M12	
	28.1	28.1	10.0	10.0	20.0	20.0	25.0	25.0	28.1	28.1
Design values	28.1	28.1	10.0	10.0	20.0	20.0	25.0	25.0	28.1	28.1
Element height [mm]	M _{Rd,A} [kNm]		M _{Rd,B} [kNm]							
180	-7.6	-9.5	-5.9	-7.8	-4.1	-6.0	-3.2	-5.1	-2.7	-4.6
200	-9.0	-11.2	-7.0	-9.2	-5.0	-7.2	-4.0	-6.2	-3.4	-5.6
220	-10.3	-12.9	-8.1	-10.6	-5.8	-8.4	-4.7	-7.3	-4.0	-6.6
240	-11.6	-14.6	-9.2	-12.1	-6.7	-9.6	-5.5	-8.4	-4.7	-7.6
260	-13.0	-16.2	-10.3	-13.5	-7.6	-10.8	-6.2	-9.5	-5.4	-8.6
280	-14.3	-17.9	-11.4	-15.0	-8.4	-12.0	-7.0	-10.6	-6.1	-9.6
Element height [mm]	V _{Rd,y} [kN]									
180–280	±13.0 ±14.5									

Load bearing capacity values for further types and for concrete strength C30/37 can be found in the type tests at www.halfen.com or on request.
→ See back cover for contact information.



The verification can be performed either in section A-A or in section B-B.

1 SDV
2 SMV
3 SZV
4 CONSTRUCTION
5 BUILDING PHYSICS

Halfen HIT Steel to Concrete Connector

HIT-SP SMV

Resistance at ultimate load capacity



Shear capacity / Moment bearing capacity

Concrete strength: C20/25 ≥ C25/30

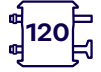

HIT-SP SMV 2M12-0210	Section A-A V _{Rd,A} [kN]		Section B-B for selected shear load V _{Rd,B} [kN]								M12
	Design values	43.9	43.9	25.0	25.0	30.0	30.0	40.0	40.0	43.9	43.9
Element height [mm]	M _{Rd,A} [kNm]		M _{Rd,B} [kNm]								
180	-7.6	-9.5	-3.2	-5.1	-2.3	-4.2	-0.6	-2.5	0.0	-1.8	
200	-9.0	-11.2	-4.0	-6.2	-3.0	-5.2	-1.0	-3.2	-0.2	-2.4	
220	-10.3	-12.9	-4.7	-7.3	-3.6	-6.2	-1.4	-4.0	-0.5	-3.1	
240	-11.6	-14.6	-5.5	-8.4	-4.2	-7.2	-1.8	-4.7	-0.8	-3.7	
260	-13.0	-16.2	-6.2	-9.5	-4.9	-8.1	-2.2	-5.4	-1.1	-4.4	
280	-14.3	-17.9	-7.0	-10.6	-5.5	-9.1	-2.6	-6.1	-1.4	-5.0	
Element height [mm]	V _{Rd,y} [kN]										
180–280	±14.7					±16.4					

Load bearing capacity values for further types and for concrete strength C30/37 can be found in the type tests at www.halfen.com or on request.
→ See back cover for contact information.

HIT-SP SMV 2M16-0208	Section A-A V _{Rd,A} [kN]		Section B-B for selected shear load V _{Rd,B} [kN]								M16
	Design values	28.1	28.1	10.0	10.0	20.0	20.0	25.0	25.0	28.1	28.1
Element height [mm]	M _{Rd,A} [kNm]		M _{Rd,B} [kNm]								
180	-13.6	-15.1	-11.8	-13.3	-10.0	-11.5	-9.1	-10.6	-8.5	-10.0	
200	-16.0	-17.8	-13.9	-15.7	-11.8	-13.7	-10.8	-12.6	-10.2	-12.0	
220	-18.1	-20.5	-15.8	-18.2	-13.5	-15.9	-12.3	-14.7	-11.6	-14.0	
240	-20.2	-23.2	-17.6	-20.6	-15.1	-18.1	-13.8	-16.8	-13.0	-16.0	
260	-22.3	-25.8	-19.5	-23.1	-16.7	-20.3	-15.3	-18.9	-14.5	-18.0	
280	-24.4	-28.4	-21.3	-25.4	-18.3	-22.4	-16.8	-20.9	-15.9	-20.0	
Element height [mm]	V _{Rd,y} [kN]										
180–280	±15.4					±17.2					

Load bearing capacity values for further types and for concrete strength C30/37 can be found in the type tests at www.halfen.com or on request.
→ See back cover for contact information.

Halfen HIT Steel to Concrete Connector

HIT-SP SMV

Resistance at ultimate load capacity



Shear capacity / Moment bearing capacity

Concrete strength: C20/25 ≥ C25/30



HIT-SP SMV 2M16-0210	Section A-A V _{Rd,A} [kN]		Section B-B for selected shear load V _{Rd,B} [kN]						M16	
Design values	43.9	43.9	25.0	25.0	30.0	30.0	40.0	40.0	43.9	43.9
Element height [mm]	M _{Rd,A} [kNm]		M _{Rd,B} [kNm]							
180	-13.6	-15.1	-9.1	-10.6	-8.2	-9.7	-6.3	-7.8	-5.6	-7.1
200	-16.0	-17.8	-10.8	-12.6	-9.8	-11.6	-7.7	-9.6	-6.9	-8.7
220	-18.1	-20.5	-12.3	-14.7	-11.2	-13.6	-8.9	-11.3	-8.0	-10.4
240	-20.2	-23.2	-13.8	-16.8	-12.5	-15.5	-10.0	-13.0	-9.0	-12.0
260	-22.3	-25.8	-15.3	-18.9	-13.9	-17.5	-11.1	-14.7	-10.1	-13.6
280	-24.4	-28.4	-16.8	-20.9	-15.3	-19.4	-12.3	-16.4	-11.1	-15.2
Element height [mm]	V _{Rd,y} [kN]									
180–280	±15.4					±17.2				

Load bearing capacity values for further types and for concrete strength C30/37 can be found in the type tests at www.halfen.com or on request.
→ See back cover for contact information.

HIT-SP SMV 2M16-0212	Section A-A V _{Rd,A} [kN]		Section B-B for selected shear load V _{Rd,B} [kN]						M16	
Design values	56.8	56.8	40.0	40.0	50.0	50.0	55.0	55.0	56.8	56.8
Element height [mm]	M _{Rd,A} [kNm]		M _{Rd,B} [kNm]							
180	-13.6	-15.1	-6.3	-7.8	-4.5	-6.0	-3.6	-5.1	-3.3	-4.8
200	-16.0	-17.8	-7.7	-9.6	-5.6	-7.5	-4.6	-6.5	-4.2	-6.1
220	-18.1	-20.5	-8.9	-11.3	-6.6	-9.0	-5.4	-7.8	-5.0	-7.4
240	-20.2	-23.2	-10.0	-13.0	-7.5	-10.5	-6.2	-9.2	-5.7	-8.7
260	-22.3	-25.8	-11.1	-14.7	-8.4	-11.9	-7.0	-10.6	-6.5	-10.1
280	-24.4	-28.4	-12.3	-16.4	-9.3	-13.4	-7.8	-11.9	-7.2	-11.3
Element height [mm]	V _{Rd,y} [kN]									
180–280	±16.4					±18.3				

Load bearing capacity values for further types and for concrete strength C30/37 can be found in the type tests at www.halfen.com or on request.
→ See back cover for contact information.



The verification can be performed either in section A-A or in section B-B.

1 SDV
2 SMV
3 SZV
4 CONSTRUCTION
5 BUILDING PHYSICS

Halfen HIT Steel to Concrete Connector

HIT-HP SMV, HIT-SP SMV

Product specifications

SDV 1

HIT-HP/SP SMV-2M16-0208 with installation aid

Section

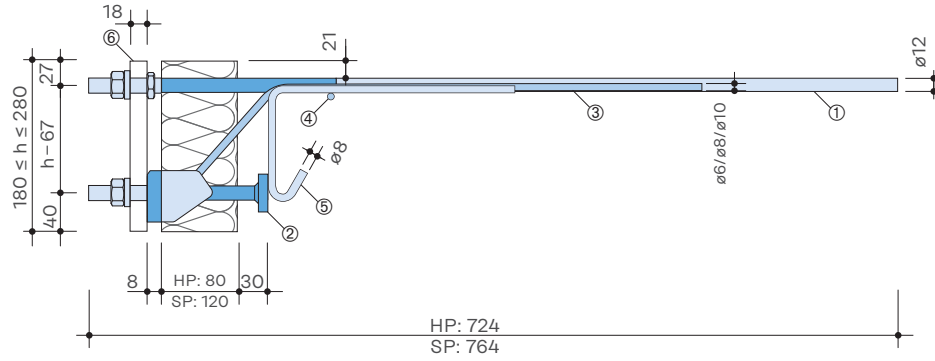

- ① Tension bar
- ② Pressure bearing
- ③ Shear load bar
- ④ Constructive installation rebar
- ⑤ Stirrup
- ⑥ Installation aid

SMV 2

Plan view

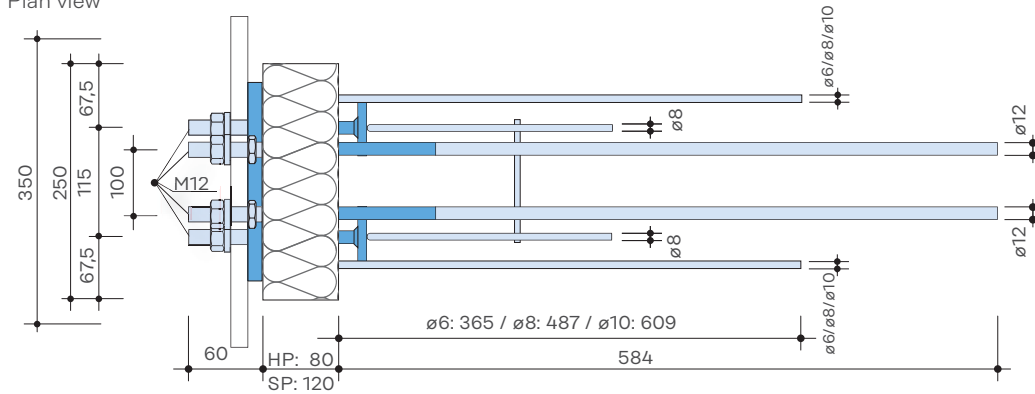

Dimensions in [mm]

SZV 3

HIT-HP/SP SMV-2M16-0210 with installation aid

Section

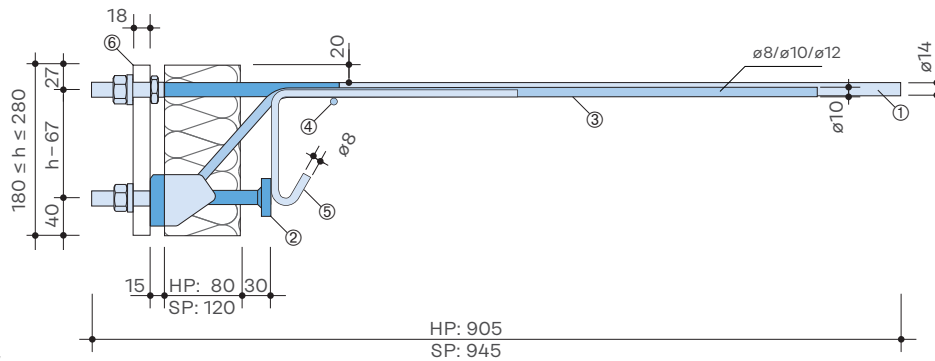

- ① Tension bar
- ② Pressure bearing
- ③ Shear bar
- ④ Constructive installation rebar
- ⑤ Stirrup
- ⑥ Installation aid

CONSTRUCTION 4

Plan view

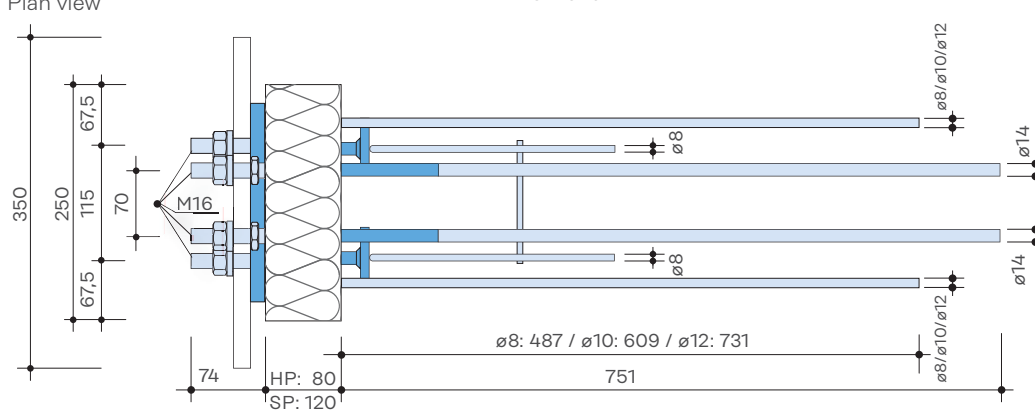

Dimensions in [mm]

BUILDING PHYSICS 5

Halfen HIT Steel to Concrete Connector

HIT-HP SMV, HIT-SP SMV

On-site connecting reinforcement

Section – On-site cast concrete

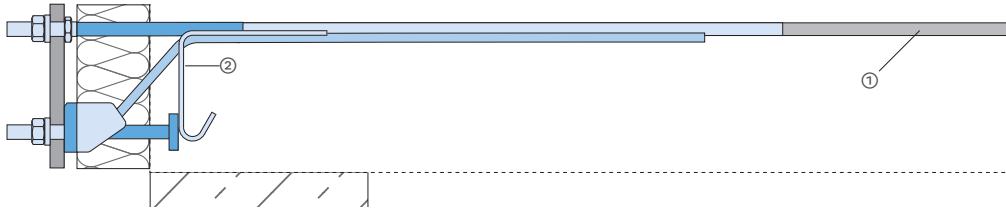

Section – Semi-precast slab

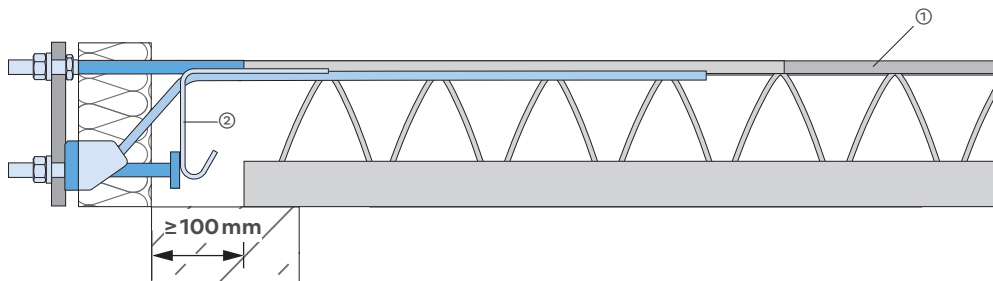

Plan view – On-site cast concrete

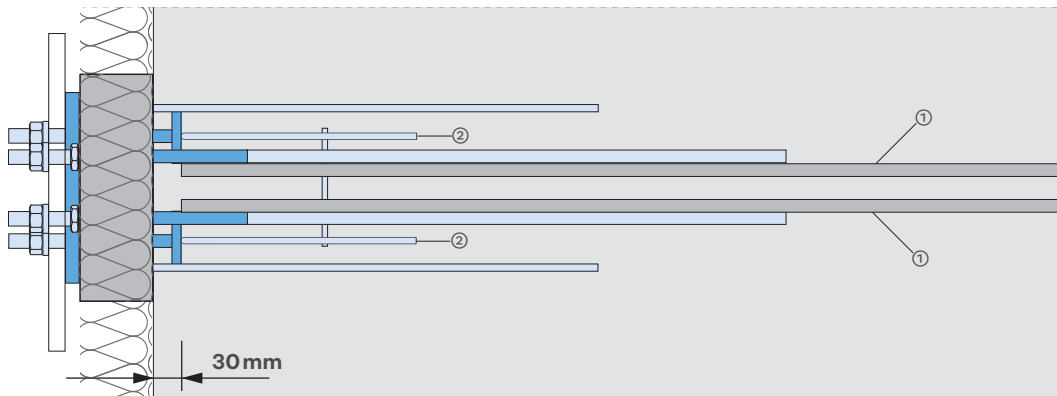

Position ①: 2 ϕ 12 for M12
2 ϕ 14 for M16;
The bar lengths are defined by the tension bar overlap as specified in the structural design plans

Position ②: 2 ϕ 8; included in the element
Figures: Overlap with the on-site connecting reinforcement

i On-site reinforcement according to the structural engineer's specifications.

i Constructive reinforcement for the free slab edge in accordance with EN 1992-1-1, horizontal min. 1 ϕ 8 mm close to the anchor heads

1 SDV

2 SMV

3 SZV

4 CONSTRUCTION

5 BUILDING PHYSICS

Halfen HIT Steel to Concrete Connector

HIT-HP SMV, HIT-SP SMV

SDV 1

Deformation

For the HIT-HP/SP SMV elements, the torsional deformations resulting from elastic girder deformation in the insulation/load inducement joint area α_M are assumed due to a standard effective moment $M_{Ed} = 1 \text{ kNm}$.

The required camber to compensate for elastic deformation of the connected steel structure can be approximated as follows:

$$\ddot{u} = \alpha_M \cdot l_k \cdot M_{Ed}$$

- with \ddot{u} = Camber [mm]
 α_M = Torque resulting from $M_{Ed} = 1 \text{ kNm}$;
 Table values in [‰/kNm]
 l_k = Span distance of cantilever [m]
 M_{Ed} = Design value of the effective moment [kNm]
 at serviceability limit state (SLS)

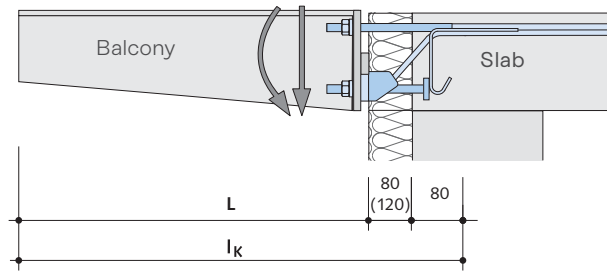

L = Cantilever length [m]
 l_k = Span distance, cantilever beam [m]

SMV 2

SVZ 3

Other deformation factors resulting from deformation of the connected steel structure must be considered by the structural engineer when determining the overall camber. The α_M values [‰/kNm] in the following table are in accordance with approval no. Z-15.7-336.

CONSTRUCTION 4

HIT-HP SMV		
α_M [‰/kNm] for element height h [mm]	HP SMV-2M12	HP SMV-2M16
180	0.928	0.572
200	0.670	0.413
220	0.506	0.312
240	0.396	0.244
260	0.318	0.196
280	0.261	0.161

BUILDING PHYSICS 5

HIT-SP SMV		
α_M [‰/kNm] for element height h [mm]	SP SMV-2M12	SP SMV-2M16
180	1.127	0.680
200	0.814	0.491
220	0.615	0.371
240	0.481	0.290
260	0.386	0.233
280	0.317	0.191

Halfen HIT Steel to Concrete Connector

HIT-HP SMV, HIT-SP SMV

Torsion spring stiffnesses

HIT-HP SMV		
Torsion spring C [kNm/rad] for element height h [mm]	HP SMV-2M12	HP SMV-2M16
180	1078	1750
200	1493	2424
220	1976	3207
240	2525	4101
260	3145	5104
280	3831	6216

HIT-SP SMV		
Torsion spring C [kNm/rad] for element height h [mm]	SP SMV-2M12	SP SMV-2M16
180	887	1470
200	1229	2037
220	1626	2695
240	2079	3446
260	2591	4289
280	3155	5224

1 SDV

2 SMV

3 SZV

4 CONSTRUCTION

5 BUILDING PHYSICS

Halfen HIT Steel to Concrete Connector

HIT-HP SMV, HIT-SP SMV

SDV 1

Axial spacing

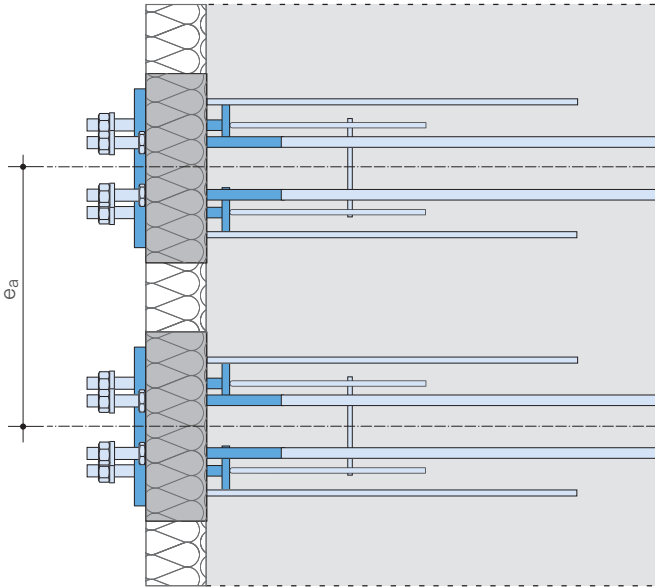

HIT Type	Axial spacing $e_a \geq$ [mm]
HIT-HP SMV-2M12	250
HIT-SP SMV-2M12	250
HIT-HP SMV-2M16	295
HIT-SP SMV-2M16	295

SMV 2

SZV 3

Edge distance

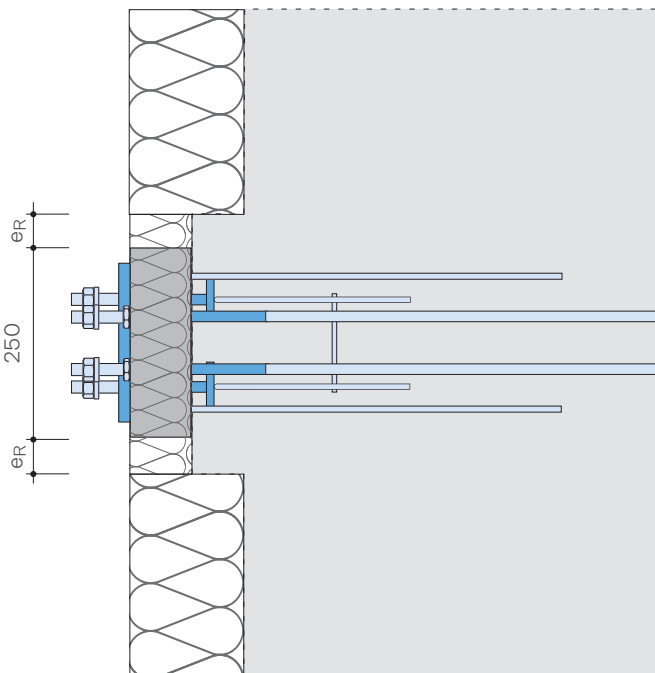

HIT Type	Edge distance e_R [mm]
HIT-HP/SP SMV-2M12-0206	0.0
HIT-HP/SP SMV-2M12-0208	13.0
HIT-HP/SP SMV-2M12-0210	22.5
HIT-HP/SP SMV-2M16-0208	22.5
HIT-HP/SP SMV-2M16-0210	22.5
HIT-HP/SP SMV-2M16-0212	33.0

CONSTRUCTION 4

BUILDING PHYSICS 5

Halfen HIT Steel to Concrete Connector

HIT-HP SMV, HIT-SP SMV

Distance from an outer corner

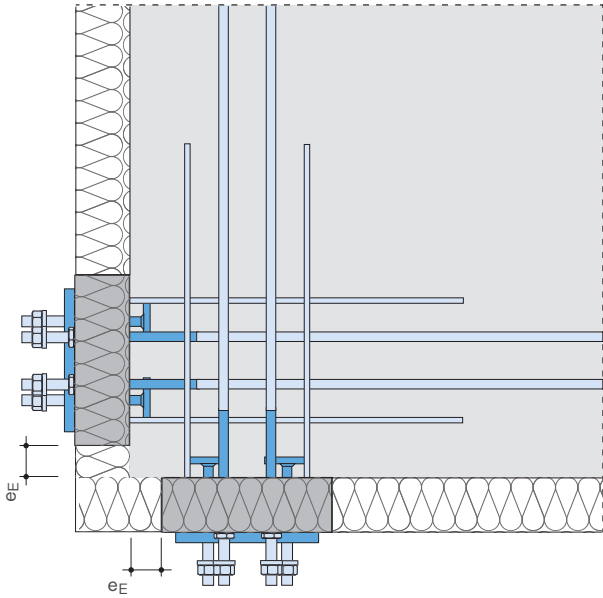

HIT Type	Axial spacing e_E [mm]
HIT-HP/SP SMV-2M12-0206	0.0
HIT-HP/SP SMV-2M12-0208	13.0
HIT-HP/SP SMV-2M12-0210	22.5
HIT-HP/SP SMV-2M16-0208	13.0
HIT-HP/SP SMV-2M16-0210	22.5
HIT-HP/SP SMV-2M16-0212	33.0

Height offset for an outer corner

To install the HIT-SMV elements at an external corner, it is necessary to offset the installation height of the elements. The required height offset is achieved using 20mm insulation strips (not included).

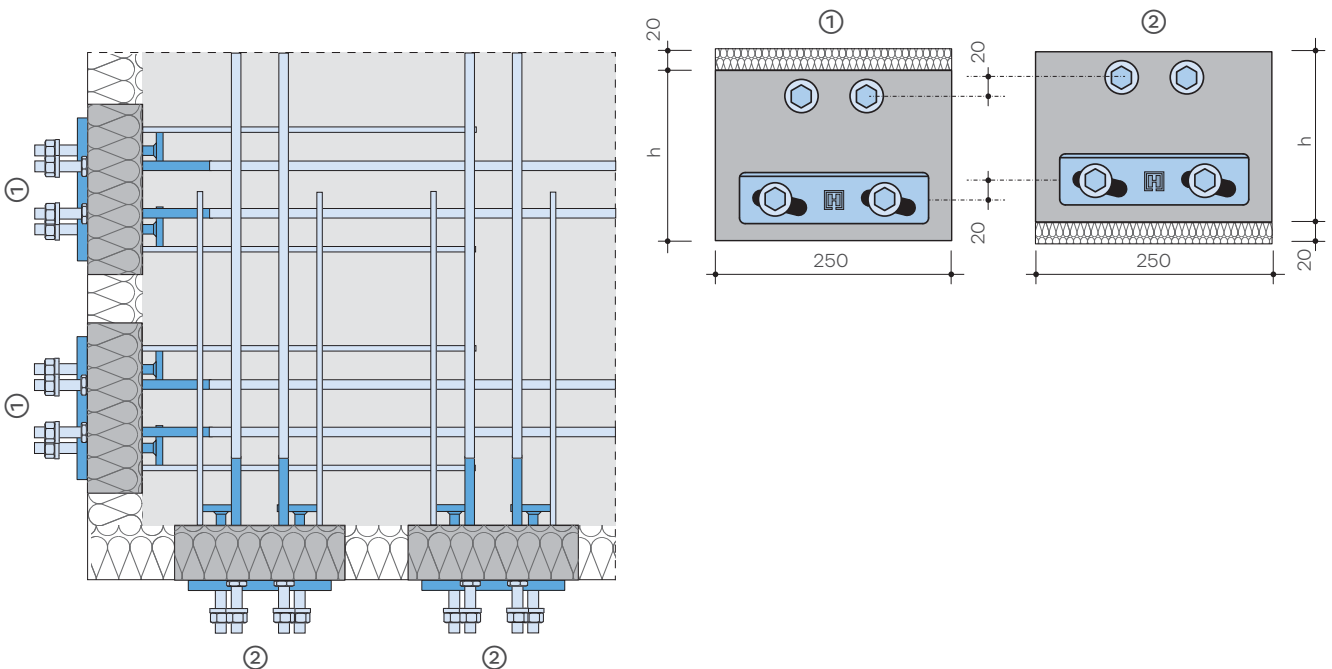

1 SDV

2 SMV

3 SZV

4 CONSTRUCTION

5 BUILDING PHYSICS

Halfen HIT Steel to Concrete Connector

HIT-HP SMV, HIT-SP SMV

Installation instructions

SDV 1

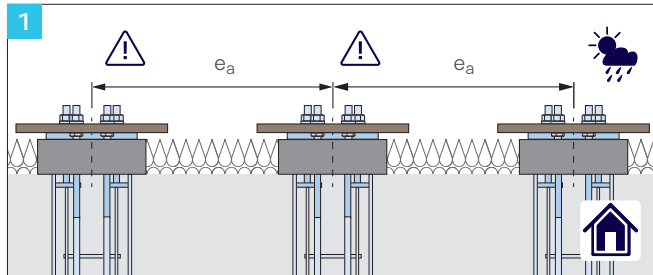

- 1** Installing the bottom reinforcement layer (example, mesh reinforcement).
Installing the HIT-Element from above.



Install the HIT Element with increased accuracy for post-installed steel elements!

SMV 2

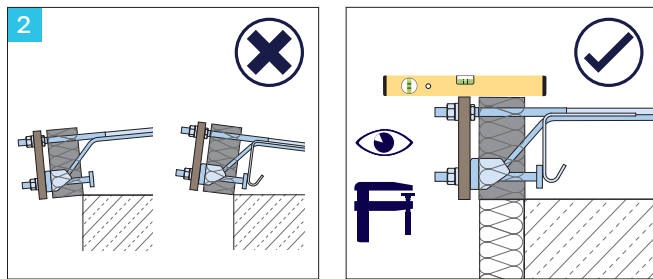

- 2** Accurate installation



Ensure installation is exactly horizontal and vertical!



Ensure the formwork is installed at the correct height!

SZV 3

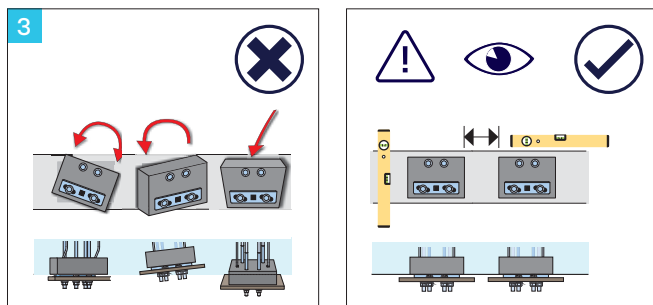

- 3** Checking horizontal and vertical alignment

The included (wood) installation aids are used to precisely align the elements; the extended edges can be used to fix to the on-site formwork as required.

Alternative: Make installation aids on-site (for example, in wood or U-profiles). Use the supplied installation aids or alternatively the our drilling templates to transfer the drill hole sizes and element distances to the on-site made installation aids.

CONSTRUCTION 4

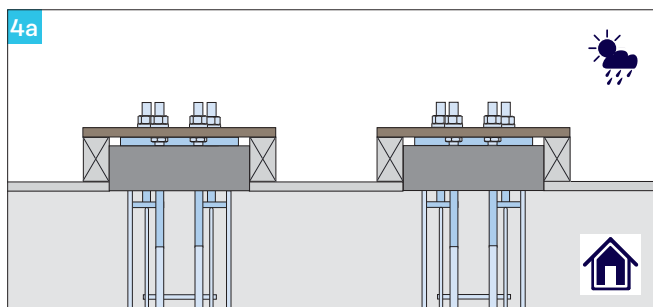

- 4** Installing the formwork

- a** Concreting directly against the formwork

BUILDING PHYSICS 5

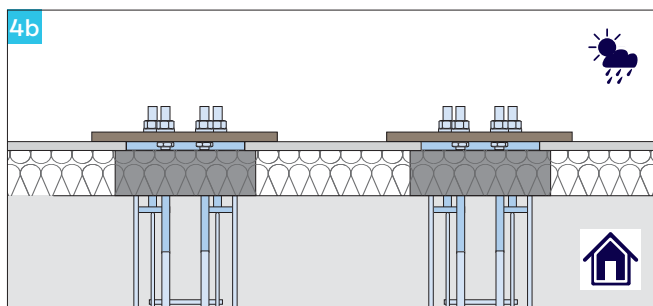

- b** Concreting directly against the insulation



A free drilling template (.pdf file) is available at:

- ▶ www.halfen.com ▶ Product Ranges ▶ Construction
- ▶ Reinforcement systems ▶ HIT Steel to Concrete Connector
- ▶ Product Information ▶ Installation Instructions

Halfen HIT Steel to Concrete Connector

HIT-HP SMV, HIT-SP SMV

Installation instructions

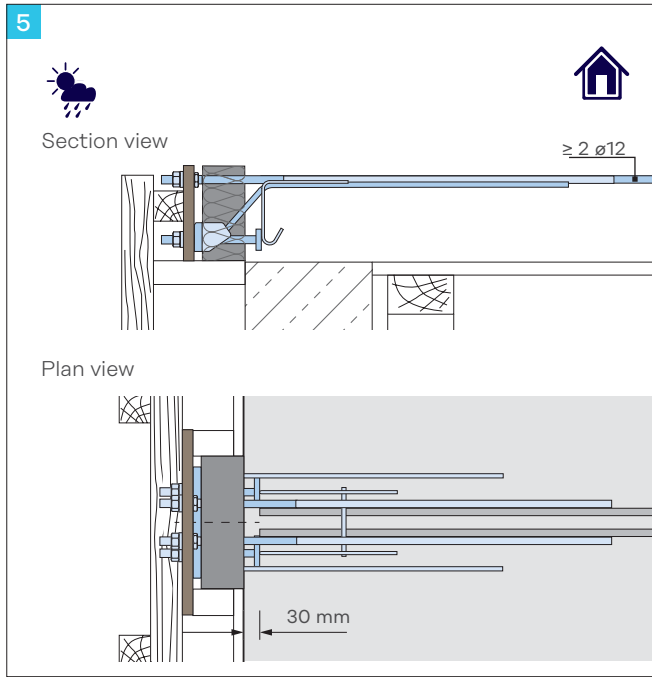

5 Installing the on-site reinforcement



On-site reinforcement must be placed as specified by the structural engineer.



Constructive reinforcement for the free slab edge in accordance with EN 1992-1-1, horizontal, min. 1 $\varnothing 8$ mm, close to the anchor heads

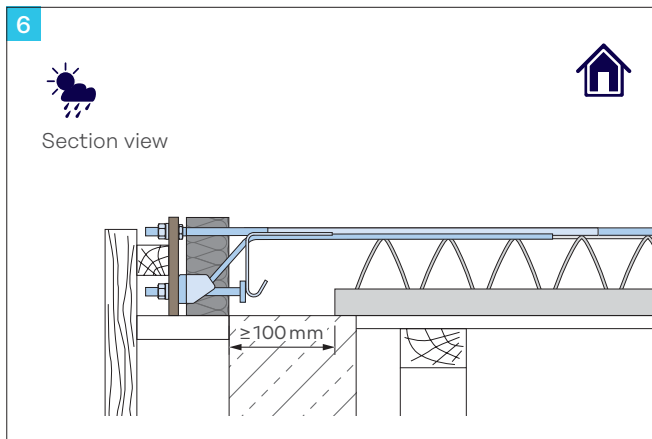

6 Installing the on-site reinforcement for semi-precast elements



On-site reinforcement must be placed as specified by the structural engineer.



Constructive reinforcement for the free slab edge in accordance with EN 1992-1-1, horizontal, min. 1 $\varnothing 8$ mm, close to the anchor heads.

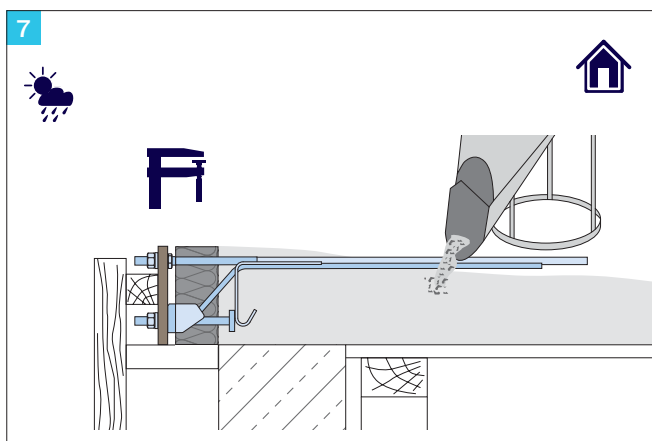

7 Pouring the concrete



To ensure the HIT units are not displaced, ensure the concrete is poured and compacted evenly.

1 SDV

2 SMV

3 SZV

4 CONSTRUCTION

5 BUILDING PHYSICS

Halfen HIT Steel to Concrete Connector

HIT-HP SZV, HIT-SP SZV

SDV

1

3

- Element for connecting supported steel constructions to reinforced concrete components
- Transfer of positive shear loads as well as horizontal forces parallel to the joint



SMV

2

SZV

3



CONSTRUCTION

4

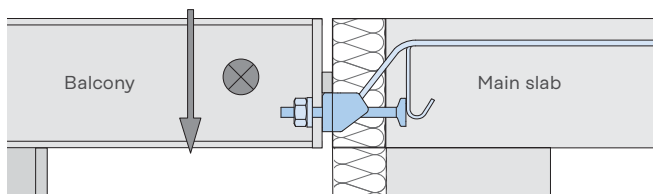

HIT-HP SZV – High Performance with 80 mm insulation
 HIT-SP SZV – Superior Performance with 120 mm insulation

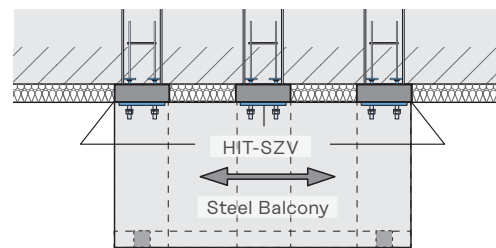

Application: Simply supported balcony slabs on columns

BUILDING PHYSICS

5

Contents	Type	Page
Load capacity range	HIT-HP SZV, HIT-SP SZV	61
Load capacity values	HIT-HP SZV, HIT-SP SZV	62
Product specifications	HIT-HP SZV, HIT-SP SZV	63
On-site connecting reinforcement	HIT-HP SZV, HIT-SP SZV	64
Axial spacing	HIT-HP SZV, HIT-SP SZV	65
Installation instructions	HIT-HP SZV, HIT-SP SZV	68

Halfen HIT Steel to Concrete Connector

HIT-HP SZV, HIT-SP SZV

Load capacity range

Combinations of four shear load capacities are available.
Anchor headed compression elements are used in the concrete slab.
Following combinations of shear load bars are possible for insulation thicknesses of HIT-HP 80mm and HIT-SP 120mm.

Element width B = 25 cm				
Number and diameter of the connection bolts, balcony side	Number and diameter of the shear load bars			
	2 ø6	2 ø8	2 ø10	2 ø12
2M12	●	●	●	
2M16		●	●	●

Auf den folgenden Seiten finden Sie die Tragfähigkeitswerte für ausgewählte Elemente ● = HP und SP

Basic types – Ordering example

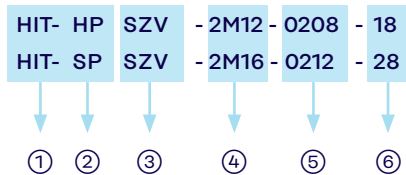

Custom Solutions

Halfen HIT Insulated connections

Our technical support team is available if a custom solution is required for your project.

Contact details: → see back cover of catalogue

Type designation

- ① Product group
- ② Joint spacing 80mm (HP) or 120mm (SP)
- ③ Connection type
- ④ Shear load range
- ⑤ Element height [cm]

Technical data

Element description HIT-HP/HIT-SP	Possible element height h [mm]	Balcony side	Main slab side			min. concrete cover slab side [mm]
		Thread	Compression bars	Shear load bars [mm]	Stirrups [mm]	C _{v,top}
SZV-2M12-0206	180–280	2M12	Anchor head	2 ø6	2 ø8	≥ 20
SZV-2M12-0208		2M12	Anchor head	2 ø8	2 ø8	≥ 20
SZV-2M12-0210		2M12	Anchor head	2 ø10	2 ø8	≥ 20
SZV-2M16-0208		2M16	Anchor head	2 ø8	2 ø8	≥ 20
SZV-2M16-0210		2M16	Anchor head	2 ø10	2 ø8	≥ 20
SZV-2M16-0212		2M16	Anchor head	2 ø12	2 ø8	≥ 20

Halfen HIT Steel to Concrete Connector

HIT-HP SZV, HIT-SP SZV

SDV 1

Resistance at ultimate load capacity



Shear load capacity

Concrete strength: C20/25 ≥ C25/30



SMV 2

HIT-HP SZV	Section A-A V _{Rd,A} [kN]						M12	M16
	HP SZV-2M12-0206		HP SZV-2M12-0208 HP SZV-2M16-0208		HP SZV-2M12-0210 HP SZV-2M16-0210		HP SZV-2M16-0212	
Design values								
Element height 180–280mm	18,8	18,8	33,5	33,5	52,3	52,3	75,3	75,3
V _{Rd,y} [kN]	4,5	5,0	4,7	5,3	4,7	5,3	4,7	5,3

Load bearing capacity values for further types and for concrete strength C30/37 can be found in the type tests at www.halfen.com or on request.
→ See back cover for contact information.

SZV 3

CONSTRUCTION 4



Shear load capacity

Concrete strength: C20/25 ≥ C25/30



HIT-SP SZV	Section A-A V _{Rd,A} [kN]						M12	M16
	SP SZV-2M12-0206		SP SZV-2M12-0208 SP SZV-2M16-0208		SP SZV-2M12-0210 SP SZV-2M16-0210		SP SZV-2M16-0212	
Design values								
Element height 180–280mm	15,8	15,8	28,1	28,1	43,9	43,9	56,8	56,8
V _{Rd,y} [kN]	4,5	5,0	4,7	5,3	4,7	5,3	4,7	5,3

Load bearing capacity values for further types and for concrete strength C30/37 can be found in the type tests at www.halfen.com or on request.
→ See back cover for contact information.

BUILDING PHYSICS 5

Halfen HIT Steel to Concrete Connector

HIT-HP SZV, HIT-SP SZV

Product description

HIT-HP/SP SZV-0208 with installation aid

Section view

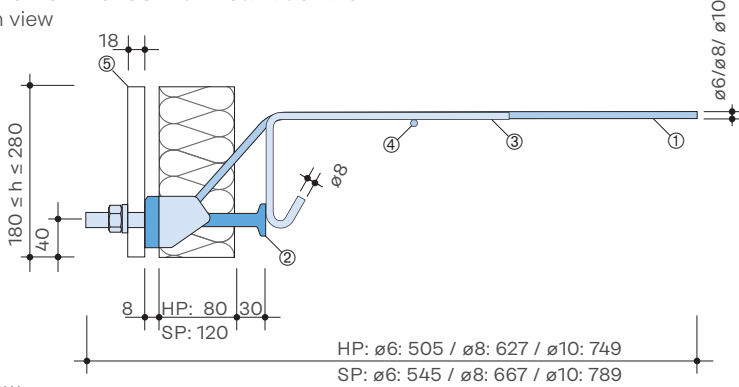

Plan view

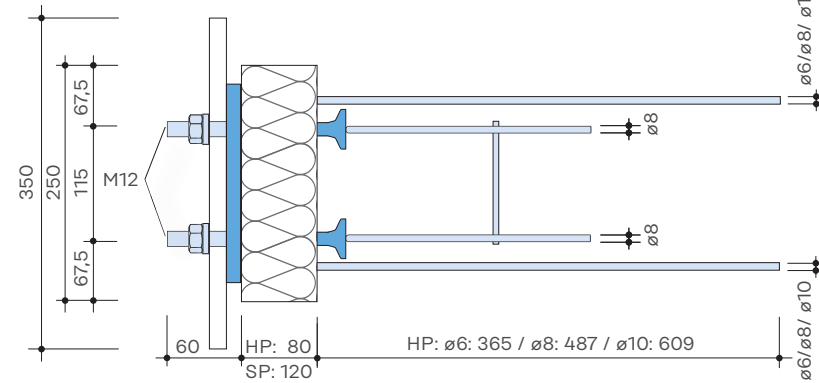

- ① Shear load bars
- ② Pressure bearing
- ③ Stirrups
- ④ Constructive installation rebar
- ⑤ Installation aid

1 SDV

2 SMV

3 SZV

Dimensions in [mm]

HIT-HP/SP SZV-0210 und HIT-HP/SP SZV-0212 with installation aid

Section view

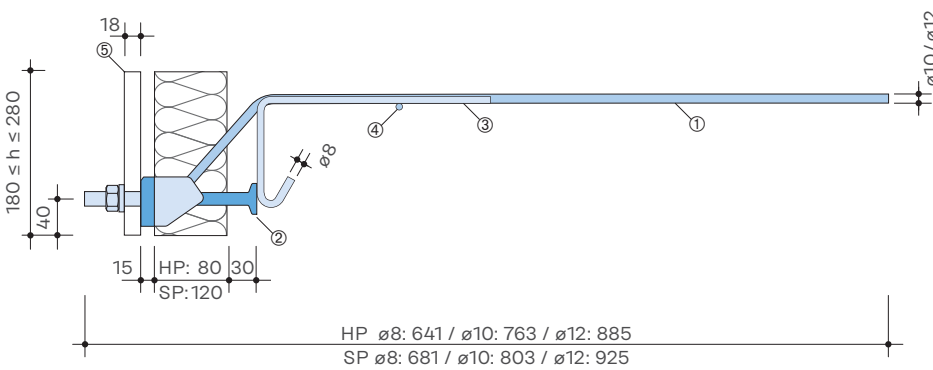

Plan view

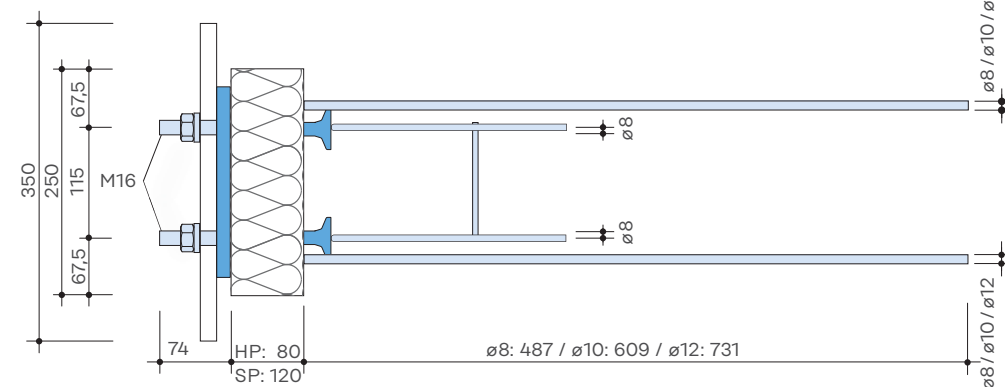

- ① Shear load bars
- ② Pressure bearing
- ③ Stirrups
- ④ Constructive installation rebar
- ⑤ Installation aid

4 CONSTRUCTION

5 BUILDING PHYSICS

Dimensions in [mm]

Halfen HIT Steel to Concrete Connector

HIT-HP SZV, HIT-SP SZV

SDV

1

On-site connecting reinforcement

Section – On-site cast concrete

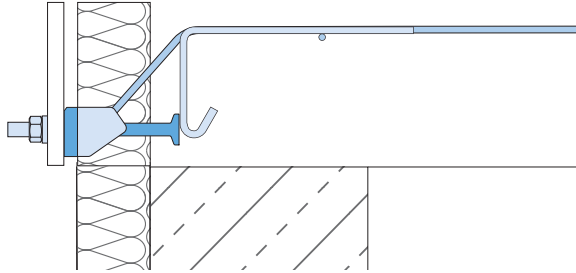

SMV

2



Constructive reinforcement for the free slab edge in accordance with EN 1992-1-1, horizontal, min. 1 \varnothing 8 mm, close to the anchor heads

SZV

3

Section – semi-precast element

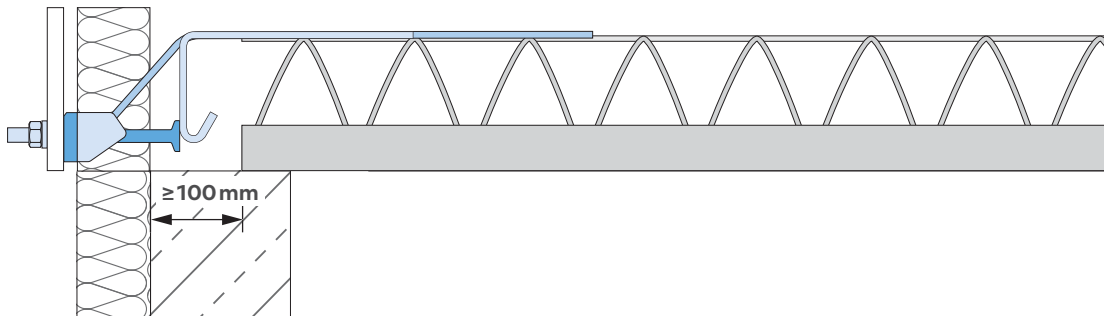

CONSTRUCTION

4



On-site reinforcement according to the structural engineer's specifications.

BUILDING PHYSICS

5

Plan view – On-site cast concrete



Halfen HIT Steel to Concrete Connector

HIT-HP SZV, HIT-SP SZV

Axial spacing

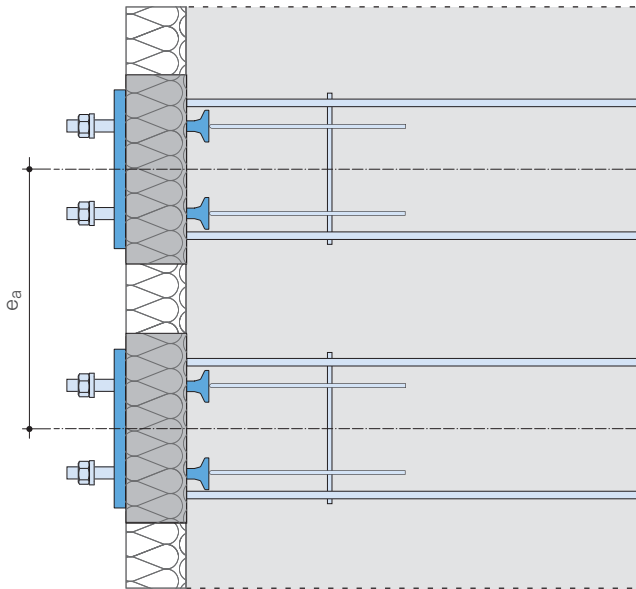

HIT Type	Axial spacing $e_a \geq$ [mm]
HIT-HP SZV-2M12	250
HIT-SP SZV-2M12	250
HIT-HP SZV-2M16	250
HIT-SP SZV-2M16	250

Edge distance

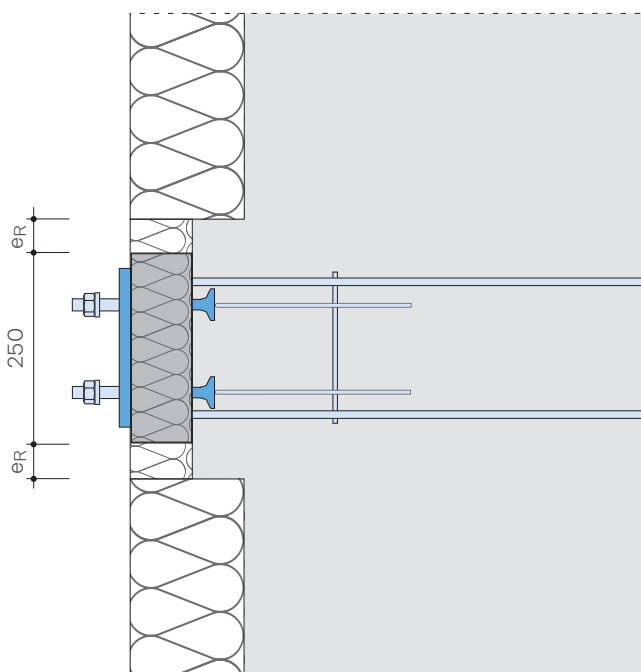

HIT Type	Distance e_R [mm]
HIT-HP/SP SZV - 2M12-0206	0
HIT-HP/SP SZV - 2M12-0208	13
HIT-HP/SP SZV - 2M12-0210	22
HIT-HP/SP SZV - 2M16-0208	13
HIT-HP/SP SZV - 2M16-0210	22
HIT-HP/SP SZV - 2M16-0212	33

1 SDV

2 SMV

3 SZV

4 CONSTRUCTION

5 BUILDING PHYSICS

Halfen HIT Steel to Concrete Connector

HIT-HP SZV, HIT-SP SZV

SDV 1

Distance from a outer corner

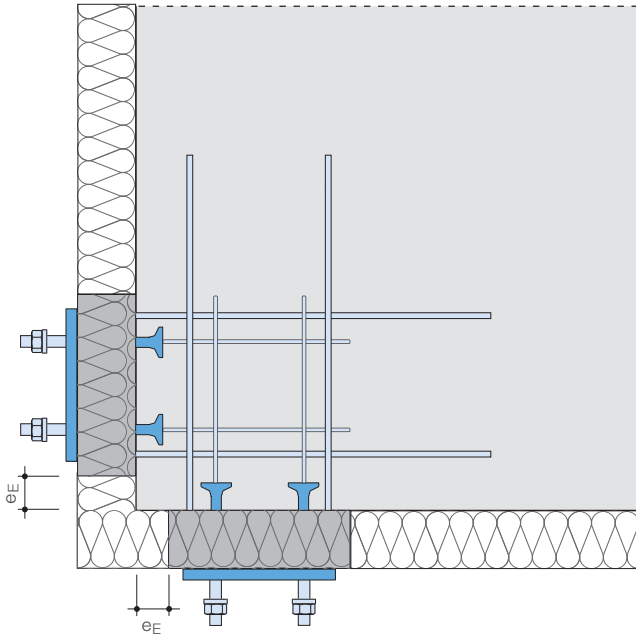

HIT Type	Distance $e_E \geq$ [mm]
HIT-HP/SP SZV - 2M12-0206	0
HIT-HP/SP SZV - 2M12-0208	13
HIT-HP/SP SZV - 2M12-0210	22
HIT-HP/SP SZV - 2M16-0208	13
HIT-HP/SP SZV - 2M16-0210	22
HIT-HP/SP SZV - 2M16-0212	33

SMV 2

SZV 3

Height-offset for an outer corner

To install the HIT-SZV elements at an external corner, it is necessary to offset the installation height of the elements. The required height offset is achieved using 20mm insulation strips (not included).

CONSTRUCTION 4

BUILDING PHYSICS 5

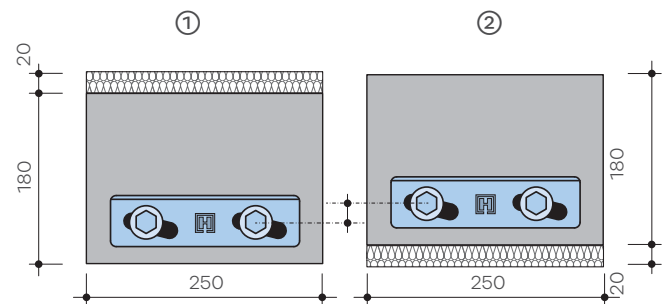
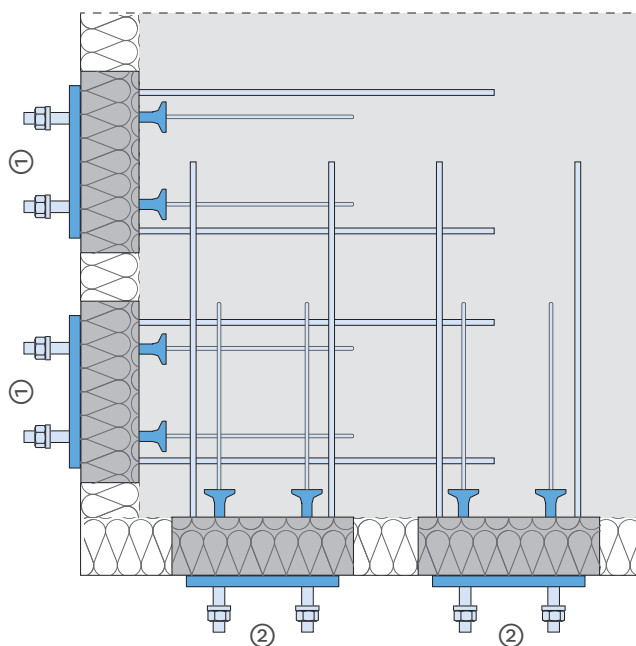

Halfen HIT Steel to Concrete Connector

HIT-HP SZV, HIT-SP SZV

Installation in concrete

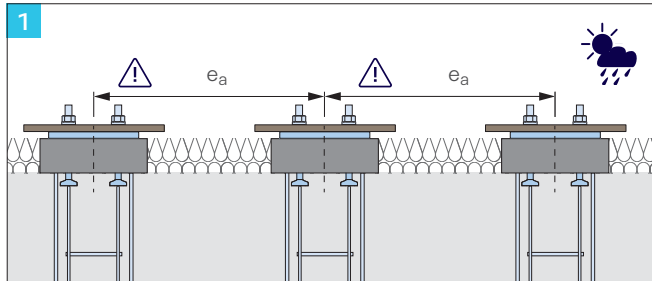

1 Installing the bottom reinforcement layer (example, mesh reinforcement). Installing the HIT-Element from above.



Install the HIT Element with increased accuracy if the steel construction is to be post-installed!

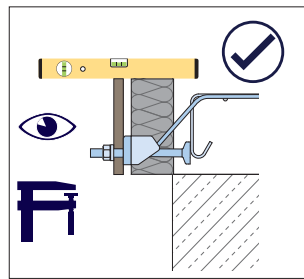
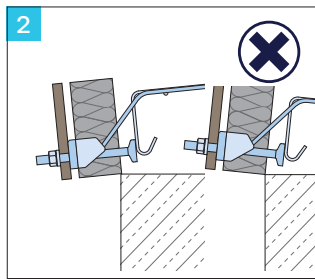

2 Accurate installation



Ensure installation is exactly horizontal and vertical!



Ensure the formwork is installed at the correct height!

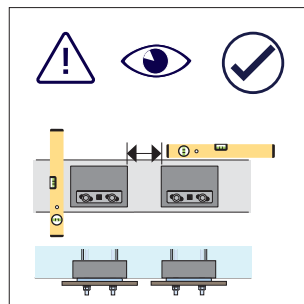
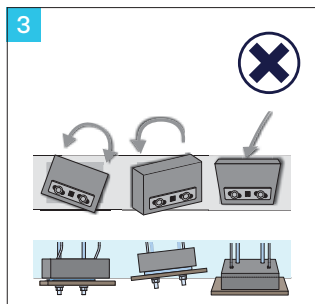

3 Checking horizontal and vertical alignment

The included (wood) installation aids are used to precisely align the elements; the extended edges can be used to fix to the on-site formwork as required.

Alternative: Make installation aids on-site (for example, in wood or U-profiles). Use the supplied installation aids or alternatively the Halfen drilling templates to transfer the drill hole sizes and element distances to the on-site made installation aids.

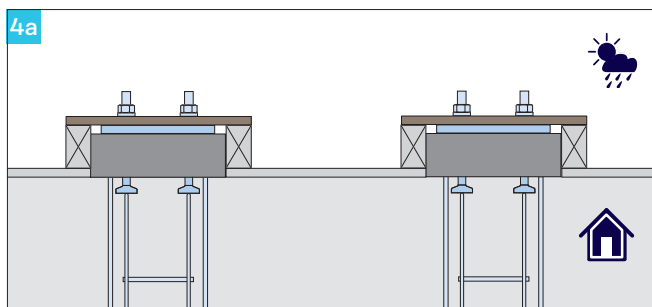

4 Installing the formwork

a Concreting directly against the formwork

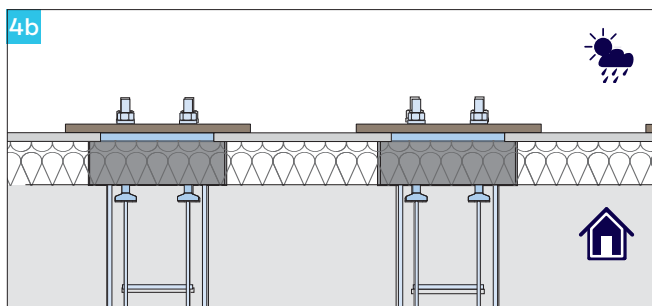

b Concreting directly against the insulation



A free drilling template (.pdf file) is available at:

- ▶ www.halfen.com ▶ Product Ranges
- ▶ Construction ▶ Reinforcement systems
- ▶ HIT Steel to Concrete Connector
- ▶ Product Information ▶ Installation Instructions

1 SDV

2 SMV

3 SZV

4 CONSTRUCTION

5 BUILDING PHYSICS

Halfen HIT Steel to Concrete Connector

HIT-HP SZV, HIT-SP SZV

SDV 1

Installation in concrete

SMV 2

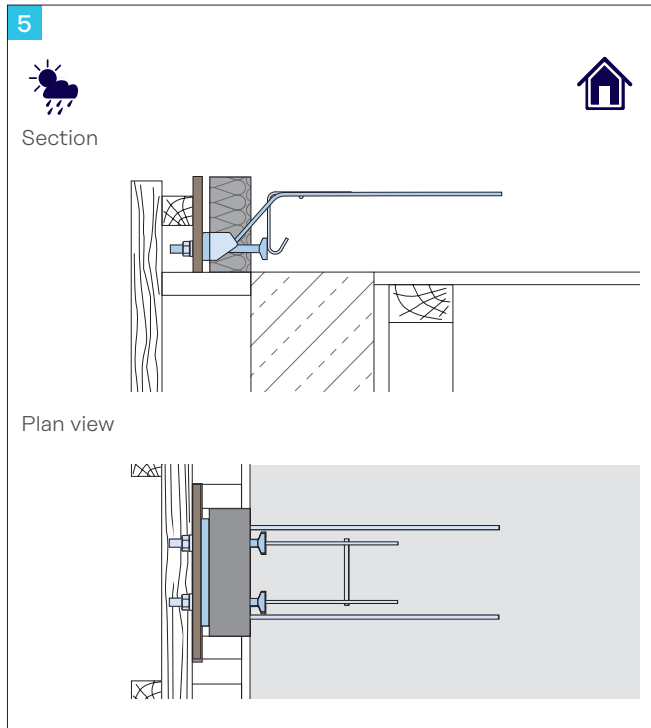

5 Installation of the on-site reinforcement



On-site reinforcement according to the structural engineer's specifications.



Constructive reinforcement for the free slab edge in accordance with EN 1992-1-1, horizontal, min. 1 \varnothing 8 mm, close to the anchor heads.

SZV 3

CONSTRUCTION 4

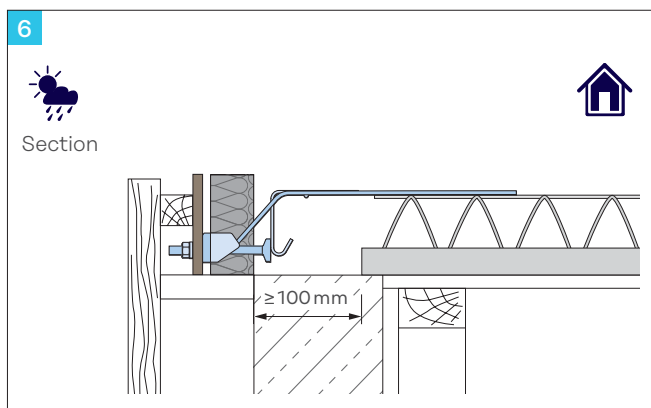

6 Installing the on-site reinforcement for a semi-precast slab



On-site reinforcement according to the structural engineer's specifications.



Constructive reinforcement for the free slab edge in accordance with EN 1992-1-1, horizontal, min. 1 \varnothing 8 mm, close to the anchor heads.

BUILDING PHYSICS 5

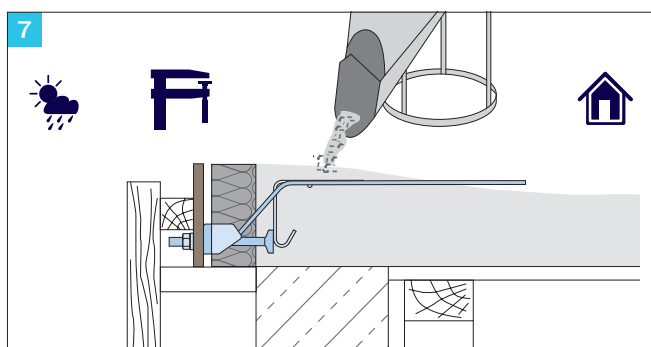

7 Pouring the concrete



To ensure the HIT elements are not displaced, ensure the concrete is poured and compacted evenly.

Halfen HIT Steel to Concrete Connector

Design and installation of the connected elements

4

■ Design and installation of connected elements



1 SDV

2 SMV

3 SZV

4 CONSTRUCTION

5 BUILDING PHYSICS

Contents

Page

On-site facing plate with notch	70
Connecting support elements	72
Installation and height adjustment	73
Installation of structural steel element	74
Expansion joint spacings	75

Halfen HIT Steel to Concrete Connector

Design and installation of the connected elements

SDV 1

On-site facing plate with notch

On-site facing plates with a notch are required to securely fasten and support connected elements to the HIT Insulated connection. The thickness of the facing plates (t_s) is specified by

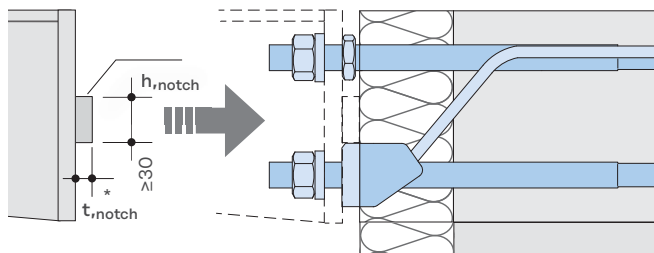

* 8 mm for M12
15 mm for M16–M22

Figure: On-site facing plate with the depth of the notch 8 mm for HIT panels with M12 or 15 mm for panels with M16/M20/M22

the structural engineer, in accordance with the defined design limits. The maximum permissible thickness ($t_{s,max}$) is determined by the available clamping length of the HIT element.

Connection thread	Clamp length	Tightening torques
M12	≤20 mm	$M_R \sim 40 \text{ Nm}$
M16	≤30 mm	$M_R = 100 \text{ Nm}$
M20	≤40 mm	$M_R \sim 150 \text{ Nm}$
M22	≤40 mm	$M_R = 200 \text{ Nm}$

SVZ 3

Shear loads are transferred from the on-site facing plate through an on-site welded notch.

For planned lifting forces (HIT-SDV), the additional second notch must be positioned in the lower area of the facing plate.

Specifications for the notch

$h_{min,notch} = 30 \text{ mm}$ (upper notch)

$h_{min,notch} = 10 \text{ mm}$ (lower notch)

$b_{min,notch} = 50 \text{ mm}$

$t_{notch} = 8 \text{ mm}$ for M12
15 mm for M16, M20, M22

Steel grade, minimum strength $f_{yk} = 235 \text{ N/mm}^2$

HV Weld seam $a_{w,min} = 4 \text{ mm}$, closed weld seam

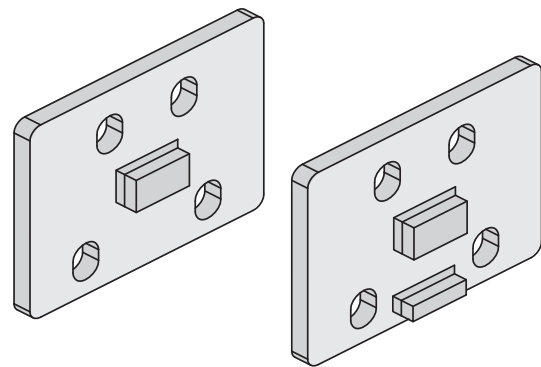

3D representation of a facing plate with welded notch (left) and with two notches (right – only for SDV with lifting forces)

CONSTRUCTION 4

Hole layout of the facing plate

The hole layout of the facing plate is determined by the bar diameter and the height of the HIT element.

Slotted holes permit vertical adjustment of the plate by up to 10 mm. The overall dimensions of the facing plate are specified by the structural engineer, who must verify the distances between the slotted holes and the outer plate edges of the facing plate.

The illustrated facing plate with the cleat, or notch, is not designed for lifting.

Facing plates should be fabricated based on local measurements of the HIT elements embedded in concrete. Corrosion protection is applied on-site only after all necessary welding work has been completed.

BUILDING PHYSICS 5

HIT-HP/SP	Connecting thread M12, M16					
HIT Element height h [mm]	180	200	220	240	260	280
$z_i = \text{hole spacing [mm]}$	113	133	153	173	193	213

HIT-HP/SP	Connecting thread M20, M22					
HIT Element height h [mm]	180	200	220	240	260	280
$z_i = \text{hole spacing [mm]}$	108	128	148	168	188	208

Halfen HIT Steel to Concrete Connector

Design and installation of the connected elements

On-site welded notch SDV

HIT-SDV M12

Hole layout for HIT-SDV with M12 thread (HIT-HP/SP SDV-2M12)

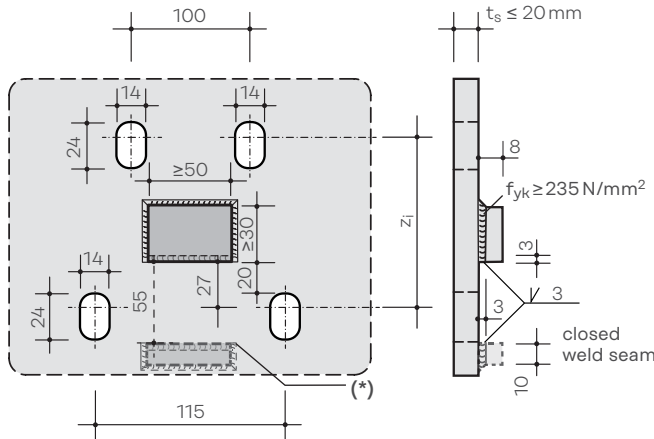

*The second notch must only be installed in the case of planned lifting shear forces (HIT-SDV).

HIT-SDV M16

Hole layout for HIT-SDV with M16 thread (HIT-HP/SP SDV-2M16)

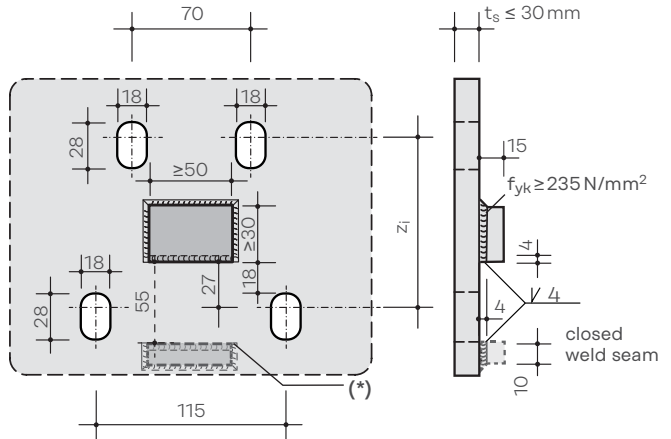

HIT-SDV M20

Hole layout for HIT-SDV with M20 thread (HIT-HP/SP SDV-2M20)

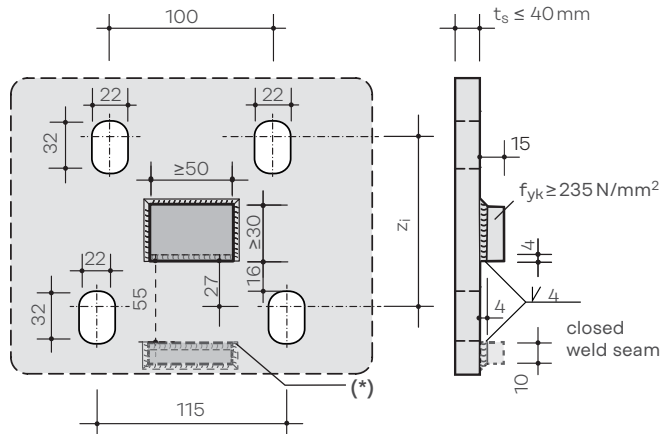

*The second notch must only be installed in the case of planned lifting shear forces (HIT-SDV).

HIT-SDV M22

Hole layout for HIT-SDV with M22 thread (HIT-HP/SP SDV-2M22)

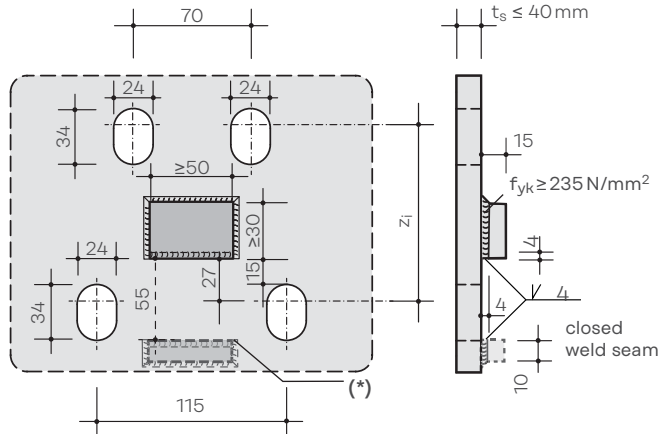

On-site welded notch SMV

HIT-SMV M12

Hole layout for HIT-SMV with M12 thread (HIT-HP/SP SMV-2M12)

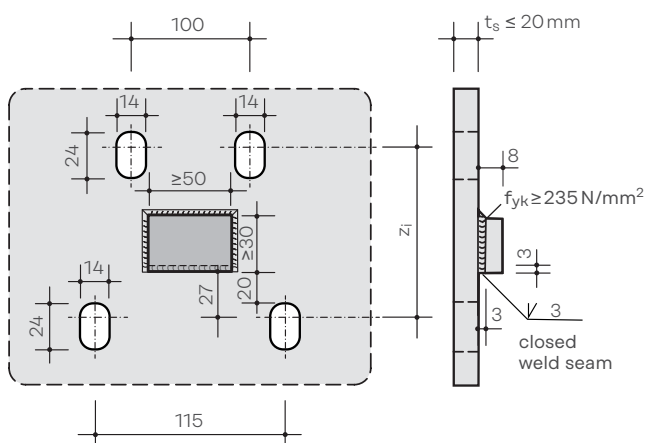

HIT-SMV M16

Hole layout for HIT-SMV with M16 thread (HIT-HP/SP SMV-2M16)

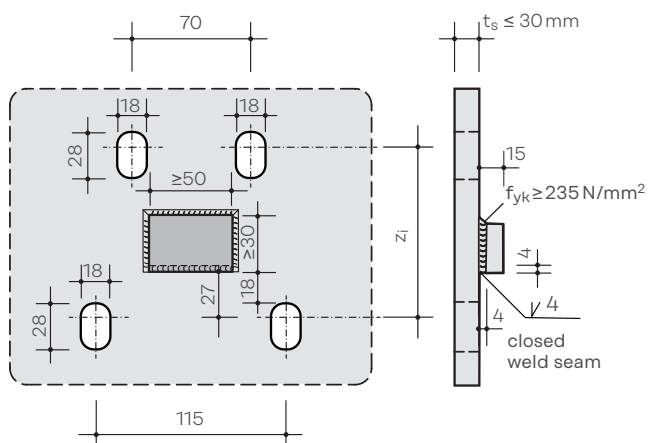

Halfen HIT Steel to Concrete Connector

Design and installation of the connected elements

On-site welded notch SZV

HIT-SZV M12

Hole layout for HIT-SZV with M12 Thread
(HIT-HP/SP SZV-2M12)

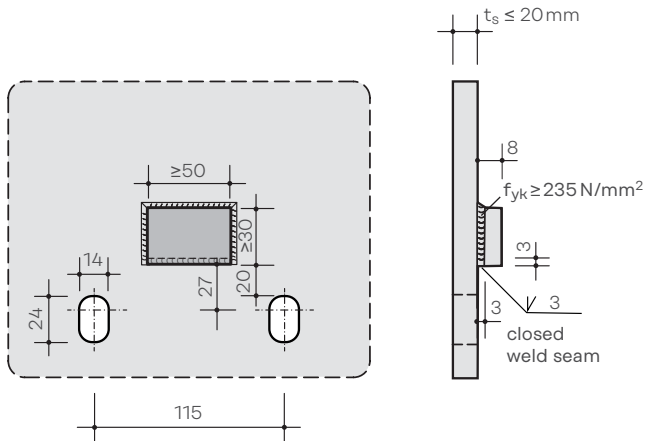

HIT-SZV M16

Hole layout for HIT-SZV with M16 Thread
(HIT-HP/SP SZV-2M16)

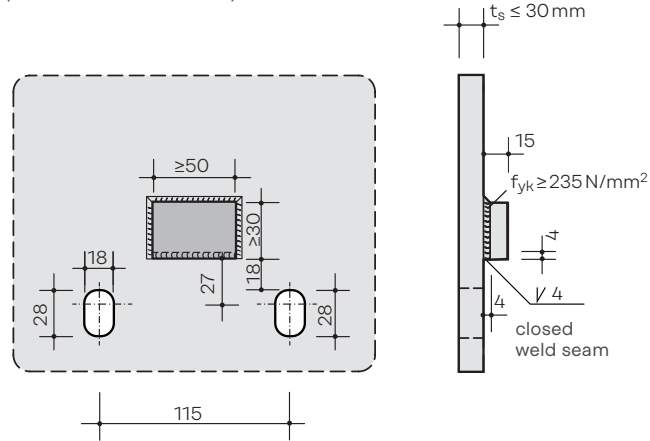

Connected steel components

The shape and dimensions of the connected steel components are specified by the structural engineer. A minimum distance (h_{LF}) must be maintained on the facing plate between:

- the top flange and the upper edge of the upper slotted hole, and
- the lower edge of the bottom slotted hole and the bottom flange.

This minimum spacing (h_{LF}), together with a height tolerance of 10 mm, determines the minimum profile dimensions required for the steel components.

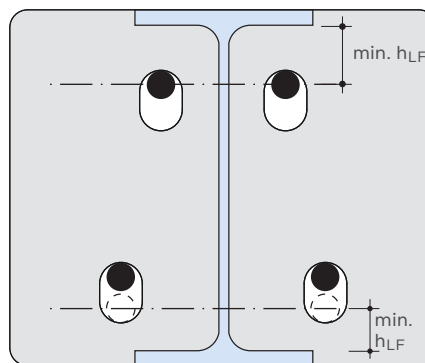

h_{LF}
M12/M16: 25 mm
M20/M22: 30 mm

Depending on the connection thread, the following min. steel profile sizes are recommended for the various HIT Element heights:

HIT-HP/SP	M12 / M16: min h_{LF} = 25 mm M20 / M22: min h_{LF} = 30 mm			
	HIT Element height	IPE	HEA	HEB
180	200	220	220	220
200	220	240	240	240
220	240	260	260	260
240	270	280	280	280
260	300	300	300	300
280	300	320	320	320

Halfen HIT Steel to Concrete Connector

Design and installation of the connected elements

Installation and height adjustment

Before installing connected components, verify the dimensions and positions of the connection threads (HIT elements) on-site. It is also recommended to confirm dimensions prior to fabrication and again before delivery if elements are manufactured off-site.

The facing plate design (see figures on pages 70–72) allows a vertical tolerance of up to 10 mm in both directions.

Height adjustment is achieved using the pre-fitted angled slotted bracket; horizontal movement of the facing plate (gently tapped into place) results in vertical displacement. For consistent tolerance in both directions, central alignment is recommended (see Figure B).

i The following should be checked before connecting steel elements to the HIT component:

- are the sizes and positions of the connection holes as specified?
- is the notch present on the facing plate?
- is the size and position of the notch as specified?

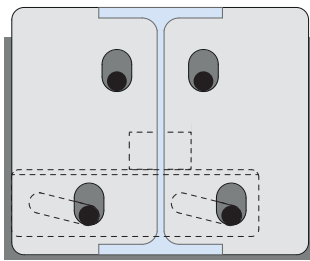

Figure A: Threaded bolt positioned at the bottom of the slot

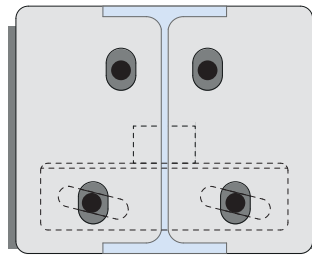

Figure A: Threaded bolt positioned at the centre of the slot

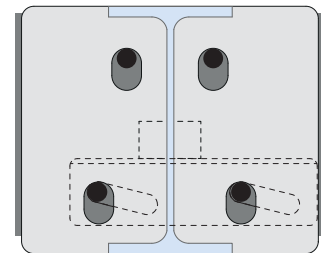
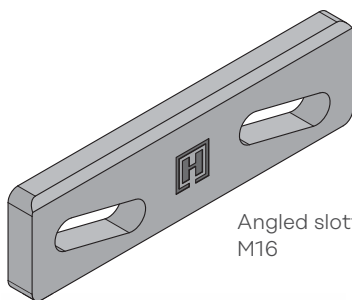
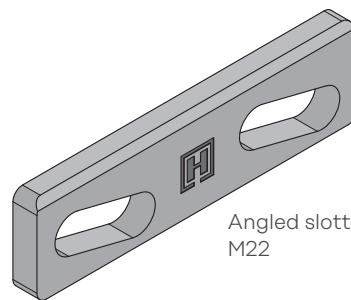

Figure A: Threaded bolt positioned at the top of the slot

i The screw threads may be shortened; a minimum of two turns of the threads must remain visible after fixing any components.



Angled slotted bracket M16



Angled slotted bracket M22

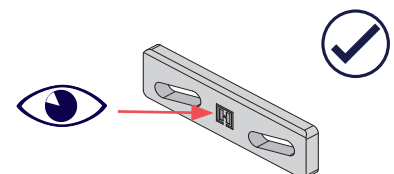
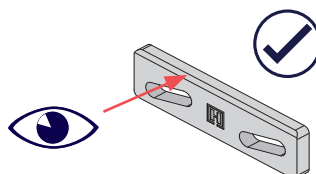

Please observe the information on the label
Correct installation of the angled slotted bracket: bevelled edge at the top, Halfen logo on the front.

Halfen HIT Steel to Concrete Connector

Design and installation of the connected elements

SDV 1

Installing of steel components

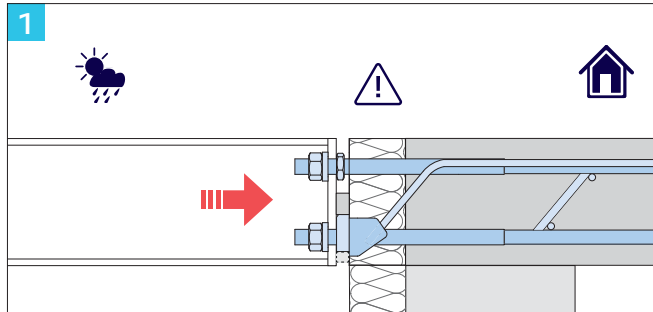

1 Fixing of steel girders

! Only use on-site end plates with notch

! **Caution:** With scheduled lifting shear forces (HIT-SDV), the additional notch at the bottom is mandatory!

SMV 2

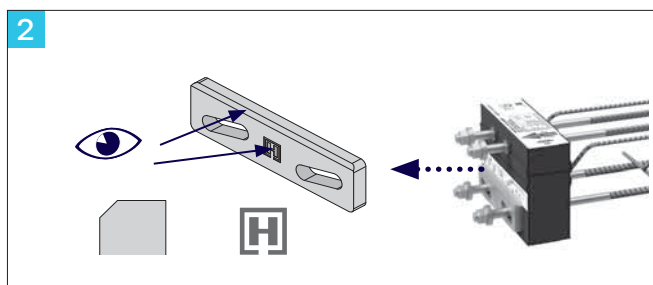

2 Please observe the information on the label

Correct orientation of the angled slotted bracket:
Halfen logo is visible, bevelled edge at the top.

SZV 3

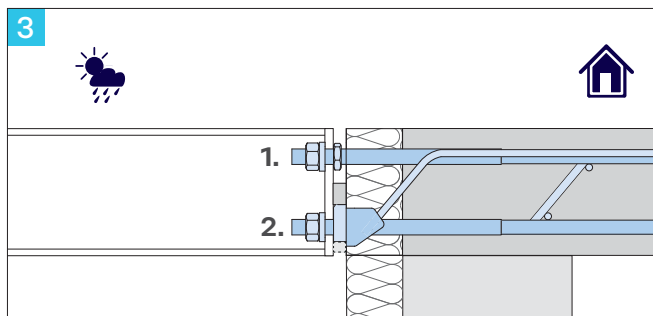

3 Fixing steel components

Attach to the top threads first, then attach to the bottom threads. Whether securing the nuts is necessary or not, must be decided by the planner.
We recommend to secure the nuts.

CONSTRUCTION 4

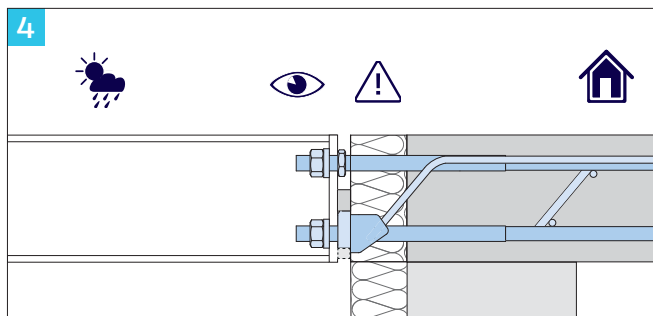

4 Check the steel connection has been installed as planned

! Check the gradient is in accordance with the design specifications! Check if the element is horizontally level or if the camber (where planned) is correct.

BUILDING PHYSICS 5

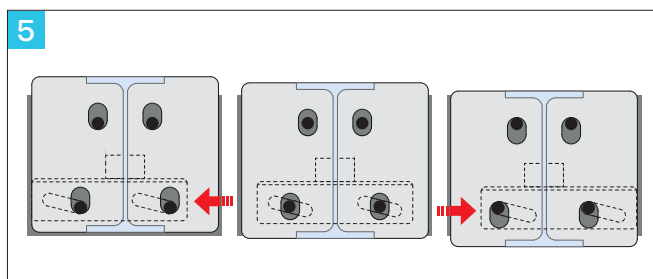

5 Final adjustment, then tighten the nuts

i The thread anchors may be shortened; ensure at least **two turns of the threads** remain visible after final installation.

Halfen HIT Steel to Concrete Connector

Design and installation of the connected elements

Expansion joint spacings

Calculation of the allowable joint spacing is in accordance with Building Authority Approval no. Z-15.7-336 and is based on a balcony slab firmly fixed to steel supports. In such cases, expansion joints must be provided in the exterior component.

The distance between the expansion joints must not exceed s_{joint} [m] for linear, cantilevered balcony slabs. Balconies designed for external corners, are limited to a maximum expansion joint spacing of $0.5 s_{\text{joint}}$ for each leg.

A limit of $0.5 s_{\text{joint}}$ per leg also applies for inner corners. s_{joint} refers to outer edge HIT to outer edge HIT. Overhang on the right and left can be included here.

If constructive measures are taken to allow expansion/contraction between the balcony slab and each steel beam — such as designing slotted holes in the cross beams — then expansion joints are not required.

Tension bar diameter in the insulation [mm]	s_{joint} max. expansion joint spacing [m]	
	HIT-HP (80 mm)	HIT-SP (120 mm)
M12	12.7	21.5
M16	9.8	16.5
M20	8.5	14.3
M22	7.9	13.3

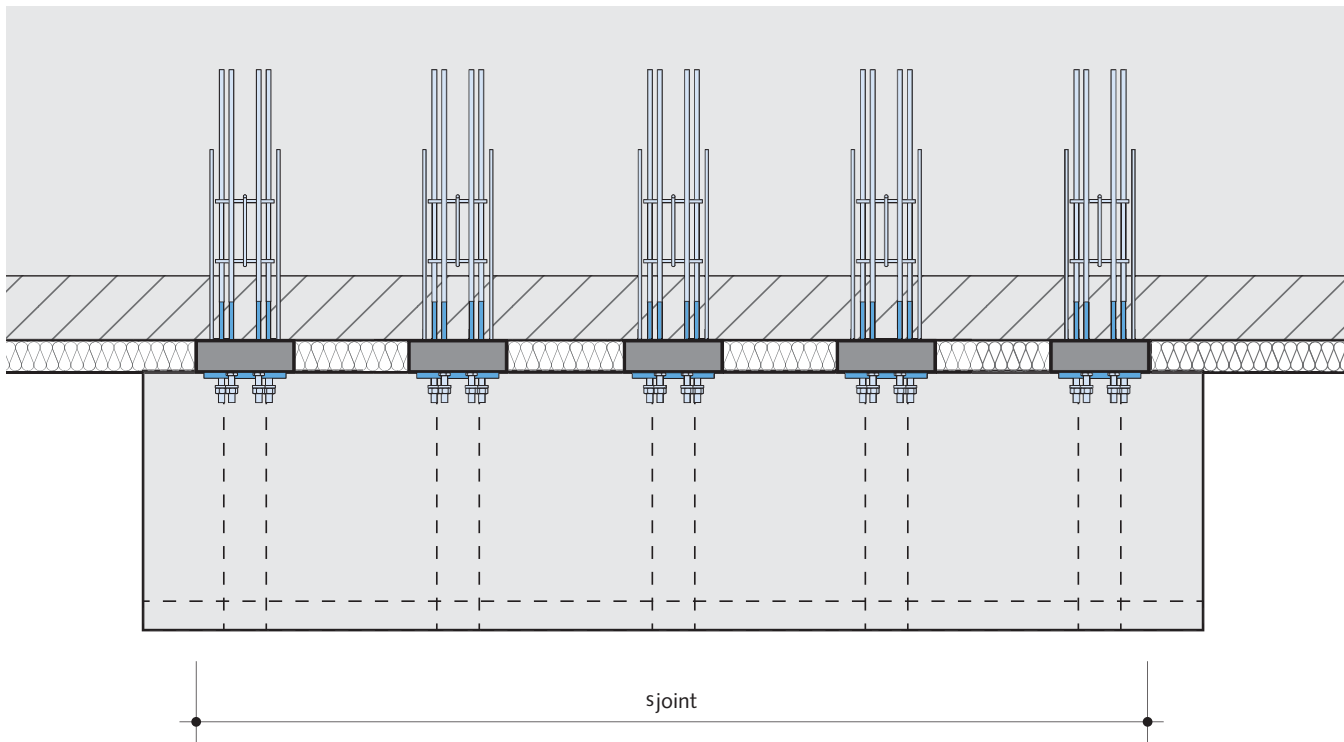

Halfen HIT Steel to Concrete Connector

Building physics

SDV 1

5

■ Building physics

The illustration of the temperature field in the horizontal section through a ceiling slab, shown here as an isothermal curve, demonstrates the excellent insulating properties of the HIT Steel to concrete connectors. These connectors form effective thermal separation of the exterior balcony components.

Their high insulation capacity prevents surface temperatures from dropping below the condensation point, thereby protecting against moisture-related damage. In addition, the efficient building physics design minimizes the risk of cracks caused by thermal expansion of the metal balcony components.

SMV 2

SZV 3

CONSTRUCTION 4

BUILDING PHYSICS 5

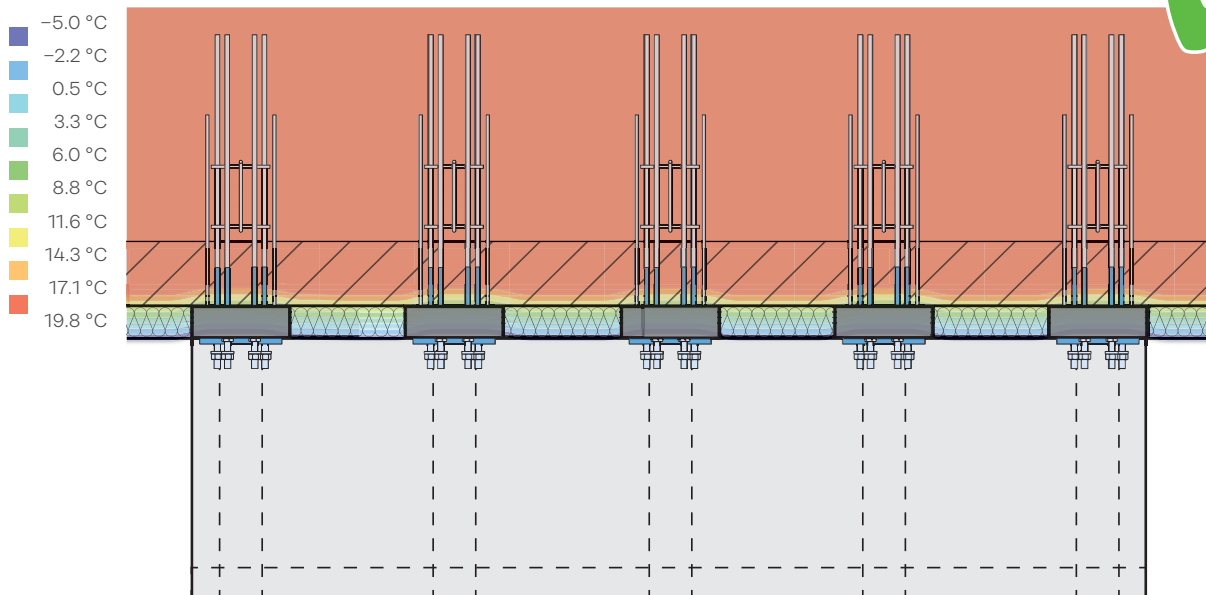

Contents

Page

Key values for thermal bridgings	77
Key values for thermal bridges according to Building Authority Approval	78
Key values for thermal bridges for HIT-HP and masonry using ETICS	88
Key values for thermal bridges for HIT-SP and masonry using ETICS	91

Halfen HIT Steel to Concrete Connector

Building physics

Key values for thermal bridges

Equivalent thermal conductivity λ_{eq}

Composite building elements, including the HIT insulated connection, consist of different building materials with different thermal conductivities.

A detailed analysis of this type of product can be very complex. To simplify the process, a homogeneous, cuboid substitute sample is assumed in the insulation joint, with the same dimensions. An equivalent thermal conductivity λ_{eq} is assigned to the substitute sample so that the total heat transfer of both systems is identical. The definition of the λ_{eq} values is based on meticulous three-dimensional thermal bridge calculations.

Calculation of the equivalent thermal conductivity is defined in Building Authority approval no. Z-15.7-336 issued by the DIBt (German Institute of Building Technology).

The λ_{eq} values cannot be used directly to calculate the primary energy demand of a building. The local thermal transfer coefficient χ can be determined using thermal bridge software, and therefore, the transmission losses can be calculated. In this case the thermal boundary conditions according to EN ISO 6946 and DIN 4108 annex 2 must be observed.

Heat transmission coefficient χ

Local thermal bridges are penetrations in the building envelope that can be referenced to a specific area.

The heat loss resulting from these thermal bridges are defined using a local thermal transfer value χ .

The χ values are therefore important variables for calculating the energy loss of local thermal bridges. The calculated values for a masonry wall using ETICS* can be found on pages 88ff.

*ETICS External Thermal Insulation Composite System.

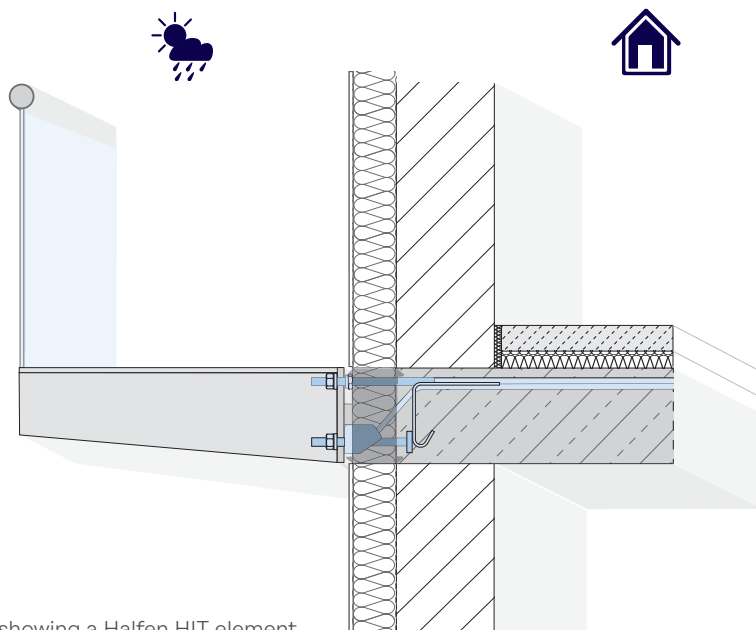

Figure: Cross section showing a Halfen HIT element, connected to a (interior) concrete slab.

1 SDV

2 SMV

3 SZV

4 CONSTRUCTION

5 BUILDING PHYSICS

Halfen HIT Steel to Concrete Connector

Building physics

Thermal values according to Building Authority Approval

The thermal characteristic values for equivalent thermal conductivity λ_{eq} and equivalent thermal resistance R_{eq} have been calculated based on Building Authority

approval no. Z-15.7-336, for all HIT Steel to concrete connections with heights from 18 to 28 cm; see the tables on the following pages.

HIT Type HP	Height [mm]	Insulation thickness [mm]	Equivalent thermal conductivity λ_{eq} [W/(mK)]	Equivalent thermal resistance R_{eq} [m ² K/W]
HIT-HP SDV-2M12-0206				
HIT-HP SDV-2M12-0206-18	180	80	0.188	0.425
HIT-HP SDV-2M12-0206-20	200	80	0.173	0.462
HIT-HP SDV-2M12-0206-22	220	80	0.161	0.498
HIT-HP SDV-2M12-0206-24	240	80	0.150	0.533
HIT-HP SDV-2M12-0206-26	260	80	0.141	0.566
HIT-HP SDV-2M12-0206-28	280	80	0.134	0.597
HIT-HP SDV-2M12-0208				
HIT-HP SMV-2M12-0208-18	180	80	0.203	0.393
HIT-HP SMV-2M12-0208-20	200	80	0.187	0.429
HIT-HP SMV-2M12-0208-22	220	80	0.173	0.462
HIT-HP SMV-2M12-0208-24	240	80	0.162	0.495
HIT-HP SMV-2M12-0208-26	260	80	0.152	0.526
HIT-HP SMV-2M12-0208-28	280	80	0.144	0.557
HIT-HP SDV-2M12-0210				
HIT-HP SDV-2M12-0210-18	180	80	0.223	0.359
HIT-HP SDV-2M12-0210-20	200	80	0.204	0.392
HIT-HP SDV-2M12-0210-22	220	80	0.189	0.423
HIT-HP SDV-2M12-0210-24	240	80	0.176	0.454
HIT-HP SDV-2M12-0210-26	260	80	0.166	0.483
HIT-HP SDV-2M12-0210-28	280	80	0.156	0.512
HIT-HP SDV-2M16-0208				
HIT-HP SDV-2M16-0208-18	180	80	0.314	0.255
HIT-HP SDV-2M16-0208-20	200	80	0.286	0.280
HIT-HP SDV-2M16-0208-22	220	80	0.263	0.304
HIT-HP SDV-2M16-0208-24	240	80	0.244	0.327
HIT-HP SDV-2M16-0208-26	260	80	0.228	0.350
HIT-HP SDV-2M16-0208-28	280	80	0.215	0.373
HIT-HP SDV-2M16-0210				
HIT-HP SDV-2M16-0210-18	180	80	0.333	0.240
HIT-HP SDV-2M16-0210-20	200	80	0.304	0.263
HIT-HP SDV-2M16-0210-22	220	80	0.279	0.286
HIT-HP SDV-2M16-0210-24	240	80	0.259	0.309
HIT-HP SDV-2M16-0210-26	260	80	0.242	0.331
HIT-HP SDV-2M16-0210-28	280	80	0.227	0.352

Halfen HIT Steel to Concrete Connector

Building physics

Thermal values according to Building Authority Approval

HIT Type HP	Height [mm]	Insulation thickness [mm]	Equivalent thermal conductivity λ_{eq} [W/(mK)]	Equivalent thermal resistance R_{eq} [m ² K/W]
HIT-HP SDV-2M16-0212				
HIT-HP SDV-2M16-0212-18	180	80	0.357	0.224
HIT-HP SDV-2M16-0212-20	200	80	0.325	0.246
HIT-HP SDV-2M16-0212-22	220	80	0.299	0.268
HIT-HP SDV-2M16-0212-24	240	80	0.277	0.289
HIT-HP SDV-2M16-0212-26	260	80	0.259	0.309
HIT-HP SDV-2M16-0212-28	280	80	0.243	0.330
HIT-HP SDV-2M20-0208				
HIT-HP SDV-2M20-0208-18	180	80	0.443	0.181
HIT-HP SDV-2M20-0208-20	200	80	0.402	0.199
HIT-HP SDV-2M20-0208-22	220	80	0.369	0.217
HIT-HP SDV-2M20-0208-24	240	80	0.341	0.234
HIT-HP SDV-2M20-0208-26	260	80	0.318	0.252
HIT-HP SDV-2M20-0208-28	280	80	0.298	0.269
HIT-HP SDV-2M20-0210				
HIT-HP SDV-2M20-0210-18	180	80	0.462	0.173
HIT-HP SDV-2M20-0210-20	200	80	0.420	0.191
HIT-HP SDV-2M20-0210-22	220	80	0.385	0.208
HIT-HP SDV-2M20-0210-24	240	80	0.356	0.225
HIT-HP SDV-2M20-0210-26	260	80	0.331	0.241
HIT-HP SDV-2M20-0210-28	280	80	0.310	0.258
HIT-HP SDV-2M20-0212				
HIT-HP SDV-2M20-0212-18	180	80	0.486	0.165
HIT-HP SDV-2M20-0212-20	200	80	0.441	0.181
HIT-HP SDV-2M20-0212-22	220	80	0.405	0.198
HIT-HP SDV-2M20-0212-24	240	80	0.374	0.214
HIT-HP SDV-2M20-0212-26	260	80	0.348	0.230
HIT-HP SDV-2M20-0212-28	280	80	0.326	0.246
HIT-HP SDV-2M22-0208				
HIT-HP SDV-2M22-0208-18	180	80	0.531	0.151
HIT-HP SDV-2M22-0208-20	200	80	0.482	0.166
HIT-HP SDV-2M22-0208-22	220	80	0.441	0.181
HIT-HP SDV-2M22-0208-24	240	80	0.407	0.196
HIT-HP SDV-2M22-0208-26	260	80	0.379	0.211
HIT-HP SDV-2M22-0208-28	280	80	0.354	0.226

1 SDV

2 SMV

3 SZV

4 CONSTRUCTION

5 BUILDING PHYSICS

Halfen HIT Steel to Concrete Connector

Building physics

Thermal values according to Building Authority Approval

HIT Type HP	Height [mm]	Insulation thickness [mm]	Equivalent thermal conductivity λ_{eq} [W/(mK)]	Equivalent thermal resistance R_{eq} [m ² K/W]
HIT-HP SDV-2M22-0210				
HIT-HP SDV-2M22-0210-18	180	80	0.551	0.145
HIT-HP SDV-2M22-0210-20	200	80	0.499	0.160
HIT-HP SDV-2M22-0210-22	220	80	0.457	0.175
HIT-HP SDV-2M22-0210-24	240	80	0.422	0.190
HIT-HP SDV-2M22-0210-26	260	80	0.392	0.204
HIT-HP SDV-2M22-0210-28	280	80	0.367	0.218
HIT-HP SDV-2M22-0212				
HIT-HP SDV-2M22-0212-18	180	80	0.575	0.139
HIT-HP SDV-2M22-0212-20	200	80	0.521	0.154
HIT-HP SDV-2M22-0212-22	220	80	0.477	0.168
HIT-HP SDV-2M22-0212-24	240	80	0.440	0.182
HIT-HP SDV-2M22-0212-26	260	80	0.409	0.196
HIT-HP SDV-2M22-0212-28	280	80	0.382	0.209
HIT-HP SMV-2M12-0206				
HIT-HP SMV-2M12-0206-18	180	80	0.188	0.425
HIT-HP SMV-2M12-0206-20	200	80	0.173	0.462
HIT-HP SMV-2M12-0206-22	220	80	0.161	0.498
HIT-HP SMV-2M12-0206-24	240	80	0.150	0.533
HIT-HP SMV-2M12-0206-26	260	80	0.141	0.566
HIT-HP SMV-2M12-0206-28	280	80	0.134	0.597
HIT-HP SMV-2M12-0208				
HIT-HP SMV-2M12-0208-18	180	80	0.203	0.393
HIT-HP SMV-2M12-0208-20	200	80	0.187	0.429
HIT-HP SMV-2M12-0208-22	220	80	0.173	0.462
HIT-HP SMV-2M12-0208-24	240	80	0.162	0.495
HIT-HP SMV-2M12-0208-26	260	80	0.152	0.526
HIT-HP SMV-2M12-0208-28	280	80	0.144	0.557
HIT-HP SMV-2M12-0210				
HIT-HP SMV-2M12-0210-18	180	80	0.223	0.359
HIT-HP SMV-2M12-0210-20	200	80	0.204	0.392
HIT-HP SMV-2M12-0210-22	220	80	0.189	0.423
HIT-HP SMV-2M12-0210-24	240	80	0.176	0.454
HIT-HP SMV-2M12-0210-26	260	80	0.166	0.483
HIT-HP SMV-2M12-0210-28	280	80	0.156	0.512

Halfen HIT Steel to Concrete Connector

Building physics

Thermal values according to Building Authority Approval

HIT Type HP	Height [mm]	Insulation thickness [mm]	Equivalent thermal conductivity λ_{eq} [W/(mK)]	Equivalent thermal resistance R_{eq} [m ² K/W]
HIT-HP SMV-2M16-0208				
HIT-HP SMV-2M16-0208-18	180	80	0.314	0.255
HIT-HP SMV-2M16-0208-20	200	80	0.286	0.280
HIT-HP SMV-2M16-0208-22	220	80	0.263	0.304
HIT-HP SMV-2M16-0208-24	240	80	0.244	0.327
HIT-HP SMV-2M16-0208-26	260	80	0.228	0.350
HIT-HP SMV-2M16-0208-28	280	80	0.215	0.373
HIT-HP SMV-2M16-0210				
HIT-HP SMV-2M16-0210-18	180	80	0.333	0.240
HIT-HP SMV-2M16-0210-20	200	80	0.304	0.263
HIT-HP SMV-2M16-0210-22	220	80	0.279	0.286
HIT-HP SMV-2M16-0210-24	240	80	0.259	0.309
HIT-HP SMV-2M16-0210-26	260	80	0.242	0.331
HIT-HP SMV-2M16-0210-28	280	80	0.227	0.352
HIT-HP SMV-2M16-0212				
HIT-HP SMV-2M16-0212-18	180	80	0.357	0.224
HIT-HP SMV-2M16-0212-20	200	80	0.325	0.246
HIT-HP SMV-2M16-0212-22	220	80	0.299	0.268
HIT-HP SMV-2M16-0212-24	240	80	0.277	0.289
HIT-HP SMV-2M16-0212-26	260	80	0.259	0.309
HIT-HP SMV-2M16-0212-28	280	80	0.243	0.330
HIT-HP SZV-2M12-0206				
HIT-HP SZV-2M12-0206-18	180	80	0.333	0.240
HIT-HP SZV-2M12-0206-20	200	80	0.304	0.263
HIT-HP SZV-2M12-0206-22	220	80	0.279	0.286
HIT-HP SZV-2M12-0206-24	240	80	0.259	0.309
HIT-HP SZV-2M12-0206-26	260	80	0.242	0.331
HIT-HP SZV-2M12-0206-28	280	80	0.227	0.352
HIT-HP SZV-2M12-0208				
HIT-HP SZV-2M12-0208-18	180	80	0.145	0.551
HIT-HP SZV-2M12-0208-20	200	80	0.134	0.595
HIT-HP SZV-2M12-0208-22	220	80	0.126	0.637
HIT-HP SZV-2M12-0208-24	240	80	0.118	0.676
HIT-HP SZV-2M12-0208-26	260	80	0.112	0.714
HIT-HP SZV-2M12-0208-28	280	80	0.107	0.749

1 SDV

2 SMV

3 SZV

4 CONSTRUCTION

5 BUILDING PHYSICS

Halfen HIT Steel to Concrete Connector

Building physics

Thermal values according to Building Authority Approval

HIT Type HP	Height [mm]	Insulation thickness [mm]	Equivalent thermal conductivity λ_{eq} [W/(mK)]	Equivalent thermal resistance R_{eq} [m ² K/W]
HIT-HP SZV-2M12-0210				
HIT-HP SZV-2M12-0210-18	180	80	0.165	0.484
HIT-HP SZV-2M12-0210-20	200	80	0.153	0.524
HIT-HP SZV-2M12-0210-22	220	80	0.142	0.563
HIT-HP SZV-2M12-0210-24	240	80	0.133	0.600
HIT-HP SZV-2M12-0210-26	260	80	0.126	0.635
HIT-HP SZV-2M12-0210-28	280	80	0.120	0.668
HIT-HP SZV-2M16-0208				
HIT-HP SZV-2M16-0208-18	180	80	0.202	0.396
HIT-HP SZV-2M16-0208-20	200	80	0.186	0.431
HIT-HP SZV-2M16-0208-22	220	80	0.172	0.465
HIT-HP SZV-2M16-0208-24	240	80	0.161	0.497
HIT-HP SZV-2M16-0208-26	260	80	0.151	0.528
HIT-HP SZV-2M16-0208-28	280	80	0.143	0.558
HIT-HP SZV-2M16-0210				
HIT-HP SZV-2M16-0210-18	180	80	0.222	0.360
HIT-HP SZV-2M16-0210-20	200	80	0.204	0.393
HIT-HP SZV-2M16-0210-22	220	80	0.189	0.424
HIT-HP SZV-2M16-0210-24	240	80	0.176	0.455
HIT-HP SZV-2M16-0210-26	260	80	0.165	0.484
HIT-HP SZV-2M16-0210-28	280	80	0.156	0.512
HIT-HP SZV-2M16-0212				
HIT-HP SZV-2M16-0212-18	180	80	0.247	0.324
HIT-HP SZV-2M16-0212-20	200	80	0.226	0.354
HIT-HP SZV-2M16-0212-22	220	80	0.209	0.383
HIT-HP SZV-2M16-0212-24	240	80	0.194	0.411
HIT-HP SZV-2M16-0212-26	260	80	0.182	0.439
HIT-HP SZV-2M16-0212-28	280	80	0.172	0.465

Halfen HIT Steel to Concrete Connector

Building physics

Thermal values according to Building Authority Approval

HIT Type SP	Height [mm]	Insulation thickness [mm]	Equivalent thermal conductivity λ_{eq} [W/(mK)]	Equivalent thermal resistance R_{eq} [m ² K/W]
HIT-SP SDV-2M12-0206				
HIT-SP SDV-2M12-0206-18	180	120	0.188	0.638
HIT-SP SDV-2M12-0206-20	200	120	0.173	0.694
HIT-SP SDV-2M12-0206-22	220	120	0.161	0.747
HIT-SP SDV-2M12-0206-24	240	120	0.150	0.799
HIT-SP SDV-2M12-0206-26	260	120	0.141	0.848
HIT-SP SDV-2M12-0206-28	280	120	0.134	0.896
HIT-SP SDV-2M12-0208				
HIT-SP SDV-2M12-0208-18	180	120	0.203	0.590
HIT-SP SDV-2M12-0208-20	200	120	0.187	0.643
HIT-SP SDV-2M12-0208-22	220	120	0.173	0.694
HIT-SP SDV-2M12-0208-24	240	120	0.162	0.742
HIT-SP SDV-2M12-0208-26	260	120	0.152	0.790
HIT-SP SDV-2M12-0208-28	280	120	0.144	0.835
HIT-SP SDV-2M12-0210				
HIT-SP SDV-2M12-0210-18	180	120	0.223	0.538
HIT-SP SDV-2M12-0210-20	200	120	0.204	0.587
HIT-SP SDV-2M12-0210-22	220	120	0.189	0.635
HIT-SP SDV-2M12-0210-24	240	120	0.176	0.681
HIT-SP SDV-2M12-0210-26	260	120	0.166	0.725
HIT-SP SDV-2M12-0210-28	280	120	0.156	0.768
HIT-SP SDV-2M16-0208				
HIT-SP SDV-2M16-0208-18	180	120	0.314	0.382
HIT-SP SDV-2M16-0208-20	200	120	0.286	0.420
HIT-SP SDV-2M16-0208-22	220	120	0.263	0.456
HIT-SP SDV-2M16-0208-24	240	120	0.244	0.491
HIT-SP SDV-2M16-0208-26	260	120	0.228	0.525
HIT-SP SDV-2M16-0208-28	280	120	0.215	0.559
HIT-SP SDV-2M16-0210				
HIT-SP SDV-2M16-0210-18	180	120	0.333	0.360
HIT-SP SDV-2M16-0210-20	200	120	0.304	0.395
HIT-SP SDV-2M16-0210-22	220	120	0.279	0.430
HIT-SP SDV-2M16-0210-24	240	120	0.259	0.463
HIT-SP SDV-2M16-0210-26	260	120	0.242	0.496
HIT-SP SDV-2M16-0210-28	280	120	0.227	0.528

1 SDV

2 SMV

3 SZV

4 CONSTRUCTION

5 BUILDING PHYSICS

Halfen HIT Steel to Concrete Connector

Building physics

Thermal values according to Building Authority Approval

HIT Type SP	Height [mm]	Insulation thickness [mm]	Equivalent thermal conductivity λ_{eq} [W/(mK)]	Equivalent thermal resistance R_{eq} [m ² K/W]
HIT-SP SDV-2M16-0212				
HIT-SP SDV-2M16-0212-18	180	120	0.357	0.336
HIT-SP SDV-2M16-0212-20	200	120	0.325	0.369
HIT-SP SDV-2M16-0212-22	220	120	0.299	0.401
HIT-SP SDV-2M16-0212-24	240	120	0.277	0.433
HIT-SP SDV-2M16-0212-26	260	120	0.259	0.464
HIT-SP SDV-2M16-0212-28	280	120	0.243	0.495
HIT-SP SDV-2M20-0208				
HIT-SP SDV-2M20-0208-18	180	120	0.443	0.271
HIT-SP SDV-2M20-0208-20	200	120	0.402	0.298
HIT-SP SDV-2M20-0208-22	220	120	0.369	0.325
HIT-SP SDV-2M20-0208-24	240	120	0.341	0.352
HIT-SP SDV-2M20-0208-26	260	120	0.318	0.378
HIT-SP SDV-2M20-0208-28	280	120	0.298	0.403
HIT-SP SDV-2M20-0210				
HIT-SP SDV-2M20-0210-18	180	120	0.462	0.260
HIT-SP SDV-2M20-0210-20	200	120	0.420	0.286
HIT-SP SDV-2M20-0210-22	220	120	0.385	0.312
HIT-SP SDV-2M20-0210-24	240	120	0.356	0.337
HIT-SP SDV-2M20-0210-26	260	120	0.331	0.362
HIT-SP SDV-2M20-0210-28	280	120	0.310	0.387
HIT-SP SDV-2M20-0212				
HIT-SP SDV-2M20-0212-18	180	120	0.486	0.247
HIT-SP SDV-2M20-0212-20	200	120	0.441	0.272
HIT-SP SDV-2M20-0212-22	220	120	0.405	0.297
HIT-SP SDV-2M20-0212-24	240	120	0.374	0.321
HIT-SP SDV-2M20-0212-26	260	120	0.348	0.345
HIT-SP SDV-2M20-0212-28	280	120	0.326	0.369
HIT-SP SDV-2M22-0208				
HIT-SP SDV-2M22-0208-18	180	120	0.531	0.226
HIT-SP SDV-2M22-0208-20	200	120	0.482	0.249
HIT-SP SDV-2M22-0208-22	220	120	0.441	0.272
HIT-SP SDV-2M22-0208-24	240	120	0.407	0.295
HIT-SP SDV-2M22-0208-26	260	120	0.379	0.317
HIT-SP SDV-2M22-0208-28	280	120	0.354	0.339

Halfen HIT Steel to Concrete Connector

Building physics

Thermal values according to Building Authority Approval

HIT Type SP	Height [mm]	Insulation thickness [mm]	Equivalent thermal conductivity λ_{eq} [W/(mK)]	Equivalent thermal resistance R_{eq} [m ² K/W]
HIT-SP SDV-2M22-0210				
HIT-SP SDV-2M22-0210-18	180	120	0.551	0.218
HIT-SP SDV-2M22-0210-20	200	120	0.499	0.240
HIT-SP SDV-2M22-0210-22	220	120	0.457	0.262
HIT-SP SDV-2M22-0210-24	240	120	0.422	0.284
HIT-SP SDV-2M22-0210-26	260	120	0.392	0.306
HIT-SP SDV-2M22-0210-28	280	120	0.367	0.327
HIT-SP SDV-2M22-0212				
HIT-SP SDV-2M22-0212-18	180	120	0.575	0.209
HIT-SP SDV-2M22-0212-20	200	120	0.521	0.230
HIT-SP SDV-2M22-0212-22	220	120	0.477	0.252
HIT-SP SDV-2M22-0212-24	240	120	0.440	0.273
HIT-SP SDV-2M22-0212-26	260	120	0.409	0.293
HIT-SP SDV-2M22-0212-28	280	120	0.382	0.314
HIT-SP SMV-2M12-0206				
HIT-SP SMV-2M12-0206-18	180	120	0.188	0.638
HIT-SP SMV-2M12-0206-20	200	120	0.173	0.694
HIT-SP SMV-2M12-0206-22	220	120	0.161	0.747
HIT-SP SMV-2M12-0206-24	240	120	0.150	0.799
HIT-SP SMV-2M12-0206-26	260	120	0.141	0.848
HIT-SP SMV-2M12-0206-28	280	120	0.134	0.896
HIT-SP SMV-2M12-0208				
HIT-SP SMV-2M12-0208-18	180	120	0.203	0.590
HIT-SP SMV-2M12-0208-20	200	120	0.187	0.643
HIT-SP SMV-2M12-0208-22	220	120	0.173	0.694
HIT-SP SMV-2M12-0208-24	240	120	0.162	0.742
HIT-SP SMV-2M12-0208-26	260	120	0.152	0.790
HIT-SP SMV-2M12-0208-28	280	120	0.144	0.835
HIT-SP SMV-2M12-0210				
HIT-SP SMV-2M12-0210-18	180	120	0.223	0.538
HIT-SP SMV-2M12-0210-20	200	120	0.204	0.587
HIT-SP SMV-2M12-0210-22	220	120	0.189	0.635
HIT-SP SMV-2M12-0210-24	240	120	0.176	0.681
HIT-SP SMV-2M12-0210-26	260	120	0.166	0.725
HIT-SP SMV-2M12-0210-28	280	120	0.156	0.768

1 SDV

2 SMV

3 SZV

4 CONSTRUCTION

5 BUILDING PHYSICS

Halfen HIT Steel to Concrete Connector

Building physics

Thermal values according to Building Authority Approval

HIT Type SP	Height [mm]	Insulation thickness [mm]	Equivalent thermal conductivity λ_{eq} [W/(mK)]	Equivalent thermal resistance R_{eq} [m ² K/W]
HIT-SP SMV-2M16-0208				
HIT-SP SMV-2M16-0208-18	180	120	0.314	0.382
HIT-SP SMV-2M16-0208-20	200	120	0.286	0.420
HIT-SP SMV-2M16-0208-22	220	120	0.263	0.456
HIT-SP SMV-2M16-0208-24	240	120	0.244	0.491
HIT-SP SMV-2M16-0208-26	260	120	0.228	0.525
HIT-SP SMV-2M16-0208-28	280	120	0.215	0.559
HIT-SP SMV-2M16-0210				
HIT-SP SMV-2M16-0210-18	180	120	0.333	0.360
HIT-SP SMV-2M16-0210-20	200	120	0.304	0.395
HIT-SP SMV-2M16-0210-22	220	120	0.279	0.430
HIT-SP SMV-2M16-0210-24	240	120	0.259	0.463
HIT-SP SMV-2M16-0210-26	260	120	0.242	0.496
HIT-SP SMV-2M16-0210-28	280	120	0.227	0.528
HIT-SP SMV-2M16-0212				
HIT-SP SMV-2M16-0212-18	180	120	0.357	0.336
HIT-SP SMV-2M16-0212-20	200	120	0.325	0.369
HIT-SP SMV-2M16-0212-22	220	120	0.299	0.401
HIT-SP SMV-2M16-0212-24	240	120	0.277	0.433
HIT-SP SMV-2M16-0212-26	260	120	0.259	0.464
HIT-SP SMV-2M16-0212-28	280	120	0.243	0.495
HIT-SP SZV-2M12-0206				
HIT-SP SZV-2M12-0206-18	180	120	0.130	0.926
HIT-SP SZV-2M12-0206-20	200	120	0.120	0.997
HIT-SP SZV-2M12-0206-22	220	120	0.113	1.063
HIT-SP SZV-2M12-0206-24	240	120	0.107	1.126
HIT-SP SZV-2M12-0206-26	260	120	0.101	1.185
HIT-SP SZV-2M12-0206-28	280	120	0.097	1.241
HIT-SP SZV-2M12-0208				
HIT-SP SZV-2M12-0208-18	180	120	0.145	0.826
HIT-SP SZV-2M12-0208-20	200	120	0.134	0.892
HIT-SP SZV-2M12-0208-22	220	120	0.126	0.955
HIT-SP SZV-2M12-0208-24	240	120	0.118	1.014
HIT-SP SZV-2M12-0208-26	260	120	0.112	1.071
HIT-SP SZV-2M12-0208-28	280	120	0.107	1.124

Halfen HIT Steel to Concrete Connector

Building physics

Thermal values according to Building Authority Approval

HIT Type SP	Height [mm]	Insulation thickness [mm]	Equivalent thermal conductivity λ_{eq} [W/(mK)]	Equivalent thermal resistance R_{eq} [m ² K/W]
HIT-SP SZV-2M12-0210				
HIT-SP SZV-2M12-0210-18	180	120	0.165	0.726
HIT-SP SZV-2M12-0210-20	200	120	0.153	0.787
HIT-SP SZV-2M12-0210-22	220	120	0.142	0.844
HIT-SP SZV-2M12-0210-24	240	120	0.133	0.900
HIT-SP SZV-2M12-0210-26	260	120	0.126	0.952
HIT-SP SZV-2M12-0210-28	280	120	0.120	1.003
HIT-SP SZV-2M16-0208				
HIT-SP SZV-2M16-0208-18	180	120	0.202	0.594
HIT-SP SZV-2M16-0208-20	200	120	0.186	0.647
HIT-SP SZV-2M16-0208-22	220	120	0.172	0.697
HIT-SP SZV-2M16-0208-24	240	120	0.161	0.746
HIT-SP SZV-2M16-0208-26	260	120	0.151	0.793
HIT-SP SZV-2M16-0208-28	280	120	0.143	0.838
HIT-SP SZV-2M16-0210				
HIT-SP SZV-2M16-0210-18	180	120	0.222	0.540
HIT-SP SZV-2M16-0210-20	200	120	0.204	0.589
HIT-SP SZV-2M16-0210-22	220	120	0.189	0.636
HIT-SP SZV-2M16-0210-24	240	120	0.176	0.682
HIT-SP SZV-2M16-0210-26	260	120	0.165	0.726
HIT-SP SZV-2M16-0210-28	280	120	0.156	0.768
HIT-SP SZV-2M16-0212				
HIT-SP SZV-2M16-0212-18	180	120	0.247	0.486
HIT-SP SZV-2M16-0212-20	200	120	0.226	0.531
HIT-SP SZV-2M16-0212-22	220	120	0.209	0.575
HIT-SP SZV-2M16-0212-24	240	120	0.194	0.617
HIT-SP SZV-2M16-0212-26	260	120	0.182	0.658
HIT-SP SZV-2M16-0212-28	280	120	0.172	0.698

1 SDV

2 SMV

3 SZV

4 CONSTRUCTION

5 BUILDING PHYSICS

Halfen HIT Steel to Concrete Connector

Building physics

Thermal bridge characteristic values for HIT-HP and wall masonry with ETICS*

The thermal bridge coefficients for the local heat transfer coefficients χ and the minimum surface temperature Θ_{si} as well as the temperature factor $f_{R,si}$ have been calculated for a wall construction using ETICS* and are available in the table.

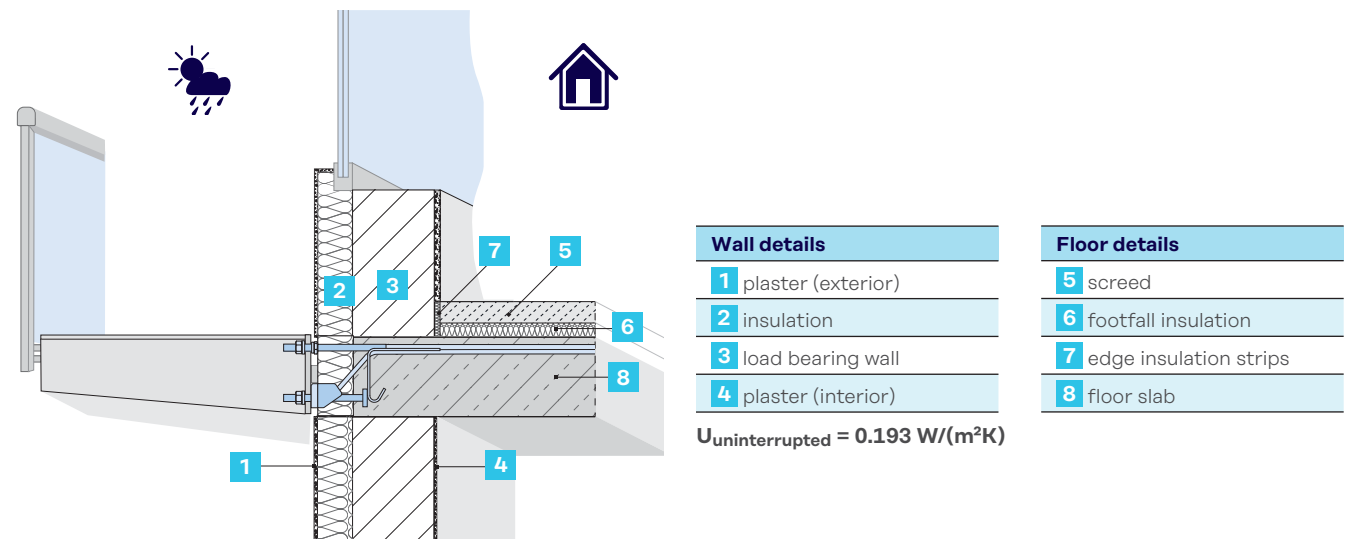

Wall detail:
Masonry with ETICS external thermal insulation composite system

HIT Type HP	Height [mm]	Insulation thickness [mm]	λ_{eq} [W/(mK)]	R_{eq} [m ² K/W]	min. Θ_{si} [°C]	$f_{R,si}$ [-]	χ [W/K]
HIT-HP SDV-2M12-0206							
HIT-HP SDV-2M12-0206-20	200	80	0.173	0.462	18.860	0.954	0.086
HIT-HP SDV-2M12-0206-28	280	80	0.134	0.597	18.880	0.955	0.094
HIT-HP SDV-2M12-0208							
HIT-HP SDV-2M12-0208-20	200	80	0.187	0.429	18.830	0.953	0.092
HIT-HP SDV-2M12-0208-28	280	80	0.144	0.557	18.850	0.954	0.100
HIT-HP SDV-2M12-0210							
HIT-HP SDV-2M12-0210-20	200	80	0.204	0.392	18.790	0.952	0.099
HIT-HP SDV-2M12-0210-28	280	80	0.156	0.512	18.810	0.952	0.107
HIT-HP SDV-2M16-0208							
HIT-HP SDV-2M16-0208-20	200	80	0.286	0.280	18.710	0.948	0.115
HIT-HP SDV-2M16-0208-28	280	80	0.215	0.373	18.760	0.950	0.123

Halfen HIT Steel to Concrete Connector

Building physics

Thermal bridge characteristic values for HIT-HP and wall masonry with ETICS*

HIT Type HP	Height [mm]	Insulation thickness [mm]	λ_{eq} [W/(mK)]	R_{eq} [m ² K/W]	min. θ_{si} [°C]	$f_{R,Si}$ [-]	χ [W/K]
HIT-HP SDV-2M16-0210							
HIT-HP SDV-2M16-0210-20	200	80	0.304	0.263	18.680	0.947	0.121
HIT-HP SDV-2M16-0210-28	280	80	0.227	0.352	18.730	0.949	0.128
HIT-HP SDV-2M16-0212							
HIT-HP SDV-2M16-0212-20	200	80	0.325	0.246	18.510	0.940	0.144
HIT-HP SDV-2M16-0212-28	280	80	0.243	0.330	18.550	0.942	0.154
HIT-HP SDV-2M20-0208							
HIT-HP SDV-2M20-0208-20	200	80	0.402	0.199	18.360	0.934	0.169
HIT-HP SDV-2M20-0208-28	280	80	0.298	0.269	18.410	0.936	0.181
HIT-HP SDV-2M20-0210							
HIT-HP SDV-2M20-0210-20	200	80	0.420	0.191	18.330	0.933	0.174
HIT-HP SDV-2M20-0210-28	280	80	0.310	0.258	18.380	0.935	0.187
HIT-HP SDV-2M20-0212							
HIT-HP SDV-2M20-0212-20	200	80	0.441	0.181	18.290	0.932	0.180
HIT-HP SDV-2M20-0212-28	280	80	0.326	0.246	18.340	0.934	0.194
HIT-HP SDV-2M22-0208							
HIT-HP SDV-2M22-0208-20	200	80	0.482	0.166	18.220	0.929	0.192
HIT-HP SDV-2M22-0208-28	280	80	0.354	0.226	18.270	0.931	0.206
HIT-HP SDV-2M22-0210							
HIT-HP SDV-2M22-0210-20	200	80	0.499	0.160	18.400	0.936	0.168
HIT-HP SDV-2M22-0210-28	280	80	0.367	0.218	18.470	0.939	0.179
HIT-HP SDV-2M22-0212							
HIT-HP SDV-2M22-0212-20	200	80	0.521	0.154	18.360	0.934	0.175
HIT-HP SDV-2M22-0212-28	280	80	0.382	0.209	18.440	0.938	0.183
HIT-HP SMV-2M12-0206							
HIT-HP SMV-2M12-0206-20	200	80	0.173	0.462	18.860	0.954	0.086
HIT-HP SMV-2M12-0206-28	280	80	0.134	0.597	18.880	0.955	0.094
HIT-HP SMV-2M12-0208							
HIT-HP SMV-2M12-0208-20	200	80	0.187	0.429	18.830	0.953	0.092
HIT-HP SMV-2M12-0208-28	280	80	0.144	0.557	18.850	0.954	0.100

*ETICS External Thermal Insulation Composite System.

Halfen HIT Steel to Concrete Connector

Building physics

Thermal bridge characteristic values for HIT-HP and wall masonry with ETICS*

HIT Type HP	Height [mm]	Insulation thickness [mm]	λ_{eq} [W/(mK)]	R_{eq} [m ² K/W]	min. θ_{si} [°C]	$f_{R,si}$ [-]	χ [W/K]
HIT-HP SMV-2M12-0210							
HIT-HP SMV-2M12-0210-20	200	80	0.204	0.392	18.790	0.952	0.099
HIT-HP SMV-2M12-0210-28	280	80	0.156	0.512	18.810	0.952	0.107
HIT-HP SMV-2M16-0208							
HIT-HP SMV-2M16-0208-20	200	80	0.286	0.280	18.710	0.948	0.115
HIT-HP SMV-2M16-0208-28	280	80	0.215	0.373	18.760	0.950	0.123
HIT-HP SMV-2M16-0210							
HIT-HP SMV-2M16-0210-20	200	80	0.304	0.263	18.680	0.947	0.121
HIT-HP SMV-2M16-0210-28	280	80	0.227	0.352	18.730	0.949	0.128
HIT-HP SMV-2M16-0212							
HIT-HP SMV-2M16-0212-20	200	80	0.325	0.246	18.510	0.940	0.144
HIT-HP SMV-2M16-0212-28	280	80	0.243	0.330	18.550	0.942	0.154
HIT-HP SZV-2M12-0206							
HIT-HP SZV-2M12-0206-20	200	80	0.120	0.665	19.010	0.960	0.063
HIT-HP SZV-2M12-0206-28	280	80	0.097	0.827	19.010	0.960	0.071
HIT-HP SZV-2M12-0208							
HIT-HP SZV-2M12-0208-20	200	80	0.134	0.595	18.970	0.959	0.069
HIT-HP SZV-2M12-0208-28	280	80	0.107	0.749	18.970	0.959	0.077
HIT-HP SZV-2M12-0210							
HIT-HP SZV-2M12-0210-20	200	80	0.153	0.524	18.920	0.957	0.078
HIT-HP SZV-2M12-0210-28	280	80	0.120	0.668	18.930	0.957	0.085
HIT-HP SZV-2M16-0208							
HIT-HP SZV-0208-20	200	80	0.186	0.431	18.920	0.957	0.083
HIT-HP SZV-0208-28	280	80	0.143	0.558	18.930	0.957	0.090
HIT-HP SZV-2M16-0210							
HIT-HP SZV-0210-20	200	80	0.204	0.393	18.880	0.955	0.089
HIT-HP SZV-0210-28	280	80	0.156	0.512	18.900	0.956	0.096
HIT-HP SZV-2M16-0212							
HIT-HP SZV-0212-20	200	80	0.226	0.354	18.840	0.954	0.095
HIT-HP SZV-0212-28	280	80	0.172	0.465	18.870	0.955	0.103

*ETICS External Thermal Insulation Composite System.

Halfen HIT Steel to Concrete Connector

Building physics

Thermal bridge characteristic values for HIT-SP and wall masonry with ETICS*

HIT Type SP	Height [mm]	Insulation thickness [mm]	λ_{eq} [W/(mK)]	R_{eq} [m ² K/W]	min. θ_{si} [°C]	$f_{R,si}$ [-]	χ [W/K]
HIT-SP SDV-2M12-0206							
HIT-SP SDV-2M12-0206-20	200	120	0.173	0.694	19.050	0.962	0.055
HIT-SP SDV-2M12-0206-28	280	120	0.134	0.896	19.070	0.963	0.059
HIT-SP SDV-2M12-0208							
HIT-SP SDV-2M12-0208-20	200	120	0.187	0.643	19.020	0.961	0.059
HIT-SP SDV-2M12-0208-28	280	120	0.144	0.835	19.050	0.962	0.063
HIT-SP SDV-2M12-0210							
HIT-SP SDV-2M12-0210-20	200	120	0.204	0.587	18.990	0.960	0.064
HIT-SP SDV-2M12-0210-28	280	120	0.156	0.768	19.020	0.961	0.069
HIT-SP SDV-2M16-0208							
HIT-SP SDV-2M16-0208-20	200	120	0.286	0.420	18.910	0.956	0.081
HIT-SP SDV-2M16-0208-28	280	120	0.215	0.559	18.950	0.958	0.084
HIT-SP SDV-2M16-0210							
HIT-SP SDV-2M16-0210-20	200	120	0.304	0.395	18.890	0.956	0.085
HIT-SP SDV-2M16-0210-28	280	120	0.227	0.528	18.930	0.957	0.088
HIT-SP SDV-2M16-0212							
HIT-SP SDV-2M16-0212-20	200	120	0.325	0.369	18.780	0.951	0.099
HIT-SP SDV-2M16-0212-28	280	120	0.243	0.495	18.820	0.953	0.011
HIT-SP SDV-2M20-0208							
HIT-SP SDV-2M20-0208-20	200	120	0.402	0.298	18.660	0.946	0.120
HIT-SP SDV-2M20-0208-28	280	120	0.298	0.403	18.710	0.948	0.127
HIT-SP SDV-2M20-0210							
HIT-SP SDV-2M20-0210-20	200	120	0.420	0.286	18.630	0.945	0.124
HIT-SP SDV-2M20-0210-28	280	120	0.310	0.387	18.690	0.948	0.131
HIT-SP SDV-2M20-0212							
HIT-SP SDV-2M20-0212-20	200	120	0.441	0.272	18.600	0.944	0.129
HIT-SP SDV-2M20-0212-28	280	120	0.326	0.369	18.660	0.946	0.137
HIT-SP SDV-2M22-0208							
HIT-SP SDV-2M22-0208-20	200	120	0.482	0.249	18.540	0.942	0.139
HIT-SP SDV-2M22-0208-28	280	120	0.354	0.339	18.600	0.944	0.147

*ETICS External Thermal Insulation Composite System.

Halfen HIT Steel to Concrete Connector

Building physics

Thermal bridge characteristic values for HIT-SP and wall masonry with ETICS*

HIT Type SP	Height [mm]	Insulation thickness [mm]	λ_{eq} [W/(mK)]	R_{eq} [m ² K/W]	min. θ_{si} [°C]	$f_{R,si}$ [-]	χ [W/K]
HIT-SP SDV-2M22-0210							
HIT-SP SDV-2M22-0210-20	200	120	0.499	0.240	18.640	0.946	0.126
HIT-SP SDV-2M22-0210-28	280	120	0.367	0.327	18.710	0.948	0.131
HIT-SP SDV-2M22-0212							
HIT-SP SDV-2M22-0212-20	200	120	0.521	0.230	18.620	0.945	0.130
HIT-SP SDV-2M22-0212-28	280	120	0.382	0.314	18.680	0.947	0.135
HIT-SP SMV-2M12-0206							
HIT-SP SMV-2M12-0206-20	200	120	0.173	0.694	19.050	0.962	0.055
HIT-SP SMV-2M12-0206-28	280	120	0.134	0.896	19.070	0.963	0.059
HIT-SP SMV-2M12-0208							
HIT-SP SMV-2M12-0208-20	200	120	0.187	0.643	19.020	0.961	0.059
HIT-SP SMV-2M12-0208-28	280	120	0.144	0.835	19.050	0.962	0.063
HIT-SP SMV-2M12-0210							
HIT-SP SMV-2M12-0210-20	200	120	0.204	0.587	18.990	0.960	0.064
HIT-SP SMV-2M12-0210-28	280	120	0.156	0.768	19.020	0.961	0.069
HIT-SP SMV-2M16-0208							
HIT-SP SMV-2M16-0208-20	200	120	0.286	0.420	18.910	0.956	0.081
HIT-SP SMV-2M16-0208-28	280	120	0.215	0.559	18.950	0.958	0.084
HIT-SP SMV-2M16-0210							
HIT-SP SMV-2M16-0210-20	200	120	0.304	0.395	18.890	0.956	0.085
HIT-SP SMV-2M16-0210-28	280	120	0.227	0.528	18.930	0.957	0.088
HIT-SP SMV-2M16-0212							
HIT-SP SMV-2M16-0212-20	200	120	0.325	0.369	18.780	0.951	0.099
HIT-SP SMV-2M16-0212-28	280	120	0.243	0.495	18.820	0.953	0.011
HIT-SP SZV-2M12-0206							
HIT-SP SZV-2M12-0206-20	200	120	0.120	0.997	19.150	0.966	0.038
HIT-SP SZV-2M12-0206-28	280	120	0.097	1.241	19.160	0.966	0.042
HIT-SP SZV-2M12-0208							
HIT-SP SZV-2M12-0208-20	200	120	0.134	0.892	19.120	0.965	0.042
HIT-SP SZV-2M12-0208-28	280	120	0.107	1.124	19.140	0.966	0.046

*ETICS External Thermal Insulation Composite System.

Halfen HIT Steel to Concrete Connector

Building physics

Thermal bridge characteristic values for HIT-SP and wall masonry with ETICS*

HIT Type SP	Height [mm]	Insulation thickness [mm]	λ_{eq} [W/(mK)]	R_{eq} [m ² K/W]	min. θ_{si} [°C]	$f_{R,Si}$ [-]	χ [W/K]
HIT-SP SZV-2M12-0210							
HIT-SP SZV-2M12-0210-20	200	120	0.153	0.787	19.090	0.964	0.049
HIT-SP SZV-2M12-0210-28	280	120	0.120	1.003	19.090	0.964	0.052
HIT-SP SZV-2M16-0208							
HIT-SP SZV-2M16-0208-20	200	120	0.482	0.249	19.070	0.963	0.055
HIT-SP SZV-2M16-0208-28	280	120	0.354	0.339	19.090	0.964	0.058
HIT-SP SZV-2M16-0210							
HIT-SP SZV-2M16-0210-20	200	120	0.499	0.240	19.050	0.962	0.059
HIT-SP SZV-2M16-0210-28	280	120	0.367	0.327	19.060	0.962	0.063
HIT-SP SZV-2M16-0212							
HIT-SP SZV-2M16-0212-20	200	120	0.521	0.230	19.010	0.960	0.065
HIT-SP SZV-2M16-0212-28	280	120	0.382	0.314	19.030	0.961	0.069

1 SDV

2 SMV

3 SZV

4 CONSTRUCTION

5 BUILDING PHYSICS



Leviat®

Innovative engineered products
and construction solutions that
allow the industry to build safer,
stronger and faster.



Contact Leviat worldwide

Australia

98 Kurrajong Avenue,
Mount Druitt, Sydney, NSW 2770
Tel: +61 - 2 8808 3100
Email: info.au@leviat.com

Austria

Leonard-Bernstein-Str. 10
Saturn Tower, 1220 Wien
Tel: +43 - 1 - 259 6770
Email: info.at@leviat.com

Belgium

Industrielaan 2
1740 Ternat
Tel: +32 - 2 - 582 29 45
Email: info.be@leviat.com

China

Room 601 Tower D,
Vantone Centre
No. A6 Chao Yang Men Wai Street
Chaoyang District
Beijing P.R. China 100020
Tel: +86 - 10 5907 3200
Email: info.cn@leviat.com

Czech Republic

Pekařská 695/10a
155 00 Praha 5
Tel: +420 - 311 - 690 060
Email: info.cz@leviat.com

Finland

Vädursgatan 5
412 50 Göteborg / Sweden
Tel: +358 (0)10 6338781
Email: info.fi@leviat.com

France

Carré Pleyel
5, Rue Pleyel
93200 Saint Denis
Tel: +33 (0)5 34 25 54 82
Email: info.fr@leviat.com

Germany

Liebigstrasse 14
40764 Langenfeld
Tel: +49 - 2173 - 970 - 0
Email: info.de@leviat.com

India

Unit S4, 902, A Wing,
Lodha iThink Techno Campus Building,
Panchpakhadi, Pokharan Road 2,
Thane, 400606
Tel: +91-022 695 33700
Email: info.in@leviat.com

Italy

Via F.lli Bronzetti 28
24124 Bergamo
Tel: +39 - 035 - 0760711
Email: info.it@leviat.com

Malaysia

28 Jalan Anggerik Mokara 31/59
Kota Kemuning,
40460 Shah Alam Selangor
Tel: +603 - 5122 4182
Email: info.my@leviat.com

Netherlands

Slachthuisweg 10
7556 AX Hengelo
Tel: +31 - 74 - 267 14 49
Email: info.nl@leviat.com

New Zealand

246D James Fletcher Drive, Otahuhu,
Auckland 2024
Tel: +64 - 9 276 2236
Email: info.nz@leviat.com

Philippines

27F Office A, Podium West Tower,
12 ADB Avenue, Ortigas Center
Mandaluyong City, 1550
Tel: +63 - 2 7957 6381
Email: info.ph@leviat.com

Poland

Ul. Obornicka 287
60-691 Poznań
Tel: +48 - 61 - 622 14 14
Email: info.pl@leviat.com

Singapore

10 Benoi Sector,
Singapore 629845
Tel: +65 - 6266 6802
Email: info.sg@leviat.com

Spain

Poligono Industrial Santa Ana
c/ Ignacio Zuloaga, 20
28522 Rivas-Vaciamadrid
Tel: +34 - 91 632 18 40
Email: info.es@leviat.com

Sweden

Vädursgatan 5
412 50 Göteborg
Tel: +46 - 31 - 98 58 00
Email: info.se@leviat.com

Switzerland

Grenzstrasse 24
3250 Lyss
Tel: +41 (0)800 22 66 00
Email: info.ch@leviat.com

United Arab Emirates

RA08 TB02, PO Box 17225
JAFZA, Jebel Ali, Dubai
Tel: +971 (0)4 883 4346
Email: info.ae@leviat.com

United Kingdom

President Way,
President Park,
Sheffield S4 7UR
Tel: +44 - 114 275 5224
Email: info.uk@leviat.com

USA / Canada

6467 S Falkenburg Road
Riverview, FL 33578
Tel: (800) 423-9140
Email: info.us@leviat.us

For countries not listed
Email: info@leviat.com

Notes regarding this document

© Protected by copyright. The information in this publication is based on state-of-the-art technology at the time of publication. In every case, project working details should be entrusted to appropriately qualified and experienced persons. Leviat shall not accept liability for the accuracy of the information in this document or for any printing errors. We reserve the right to make technical and design changes at any time. With a policy of continuous product development, Leviat reserves the right to modify product design and specification at any time.

