

Plaka Couplerbox

Joining system with couplers



Leviat®

We imagine, model and make engineered products and innovative construction solutions that help turn architectural visions into reality and enable our construction partners to build better, safer, stronger and faster.

Leviat is a world leader in connecting, fixing, lifting and anchoring technology.

From the build of new schools, hospitals, homes and infrastructure, to the repair and maintenance of heritage structures, our engineering skills are making a difference around the world.

We provide technical design assistance at every stage of a project, from initial planning to installation and beyond.

Our technical support services range from simple product selection through to the development of a fully customised project-specific design solution.

Every promise we make locally, has the commitment and dedication of our global team behind it. We employ almost 3,000 people at 60 locations across North America, Europe and Asia-Pacific, providing an agile and responsive service worldwide.



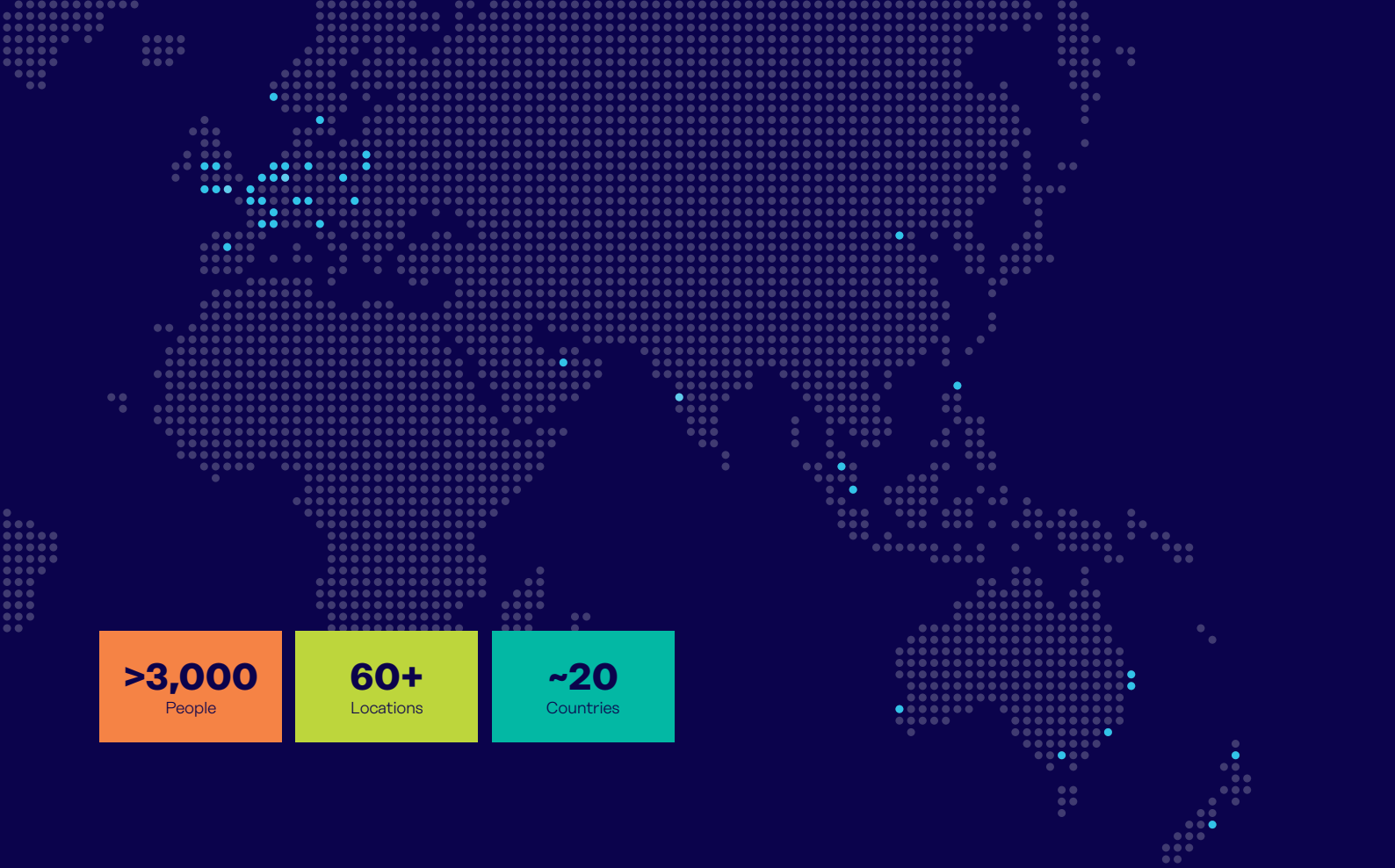

>3,000
People

60+
Locations

~20
Countries

Our areas of expertise:

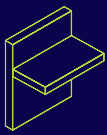

Structural Connections

Systems to form robust, efficient connections, and continuity of concrete reinforcement as necessary, between walls, slabs, columns, beams and balconies, providing structural integrity as well as enhanced thermal and acoustic performance.

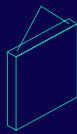

Lifting & Bracing

Systems for the safe and efficient transportation, lifting and temporary bracing of cast concrete elements and tilt-up panels before permanent structural connections are made.



Façade Support & Restraint

Systems for the safe and thermally-efficient fixing of the external building envelope, including brick and natural stone, insulated sandwich panels, curtain walling and suspended concrete façades, and also the repair and strengthening of existing masonry installations.

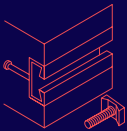

Anchoring & Fixing

Systems for fixing secondary fixtures to concrete, including anchor channels, bolts and inserts; also tension rod systems for roofs and canopies.



Formwork & Site Accessories

Non-structural accessories that complement our engineered solutions and help keep your construction environment operating safely and efficiently, including moulds for casting standard and special concrete elements and construction essentials such as reinforcing bar spacers.

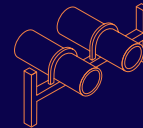

Industrial Technology

Mounting channels, pipe clamps and other versatile framing systems that provide safe fixing in a wide range of industrial applications.

Leviat product ranges:

Ancon | Aschwanden | Connolly | Halfen | Helifix | Isedio | Meadow Burke | Modersohn | Moment | Plaka | Scaldex | Thermomass

Due to our special parallel rolled thread, the Coupler Box jointing system combines safety with excellent technical performance. The couplers help the connection to provide good resistance to static and dynamic loads.

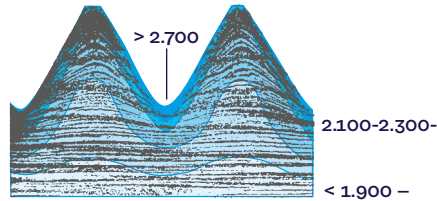

Vickers hardness N/mm²

Parallel rolled thread

The advantage of the parallel thread over tapered thread is that resistance is maintained even when screwed 2 or 3 turns too short. This can occur when debris (dirt/concrete) enters the coupler before the second phase bar is installed.

Unlike thread cutting, thread rolling does not scratch the steel and therefore causes no crack initiation (fatigue). By bending the fibres without cutting them, the material is pushed back into the mass so that the section, as well as the resistance and the hardness is increased.



Advantages

- Complies with the criteria determined in the various European standards and has approval (Zulassung) in Germany
- The coupling may be treated as a continuous bar
- Lengthening the joint (Agt) by the maximum load amounts to minimum 4%
- After 3 consecutive load cycles at 60% of the yield strength and then back to the rest position, the permanent lengthening of the connection is $\leq 0,1$ mm
- Provides very good resistance to dynamic loads

Due to its excellent properties, this system has been used on various High Speed Train sites in Europe.



Couplerbox Various types

CA type

Straight bar for the first phase supplied with a coupler at one end. The coupler is manually screwed on and glued to ensure that it does not become unscrewed during transport and handling.



CR type

Straight bar for the second phase supplied with a thread at one end.



CAC type

Straight bar for the first phase, bent at an angle of 90° or according to specifications. The diameters of the mandrels (dBr) as well as the minimum length L_1 , limited by the diameter of the bars, are shown in the table below.

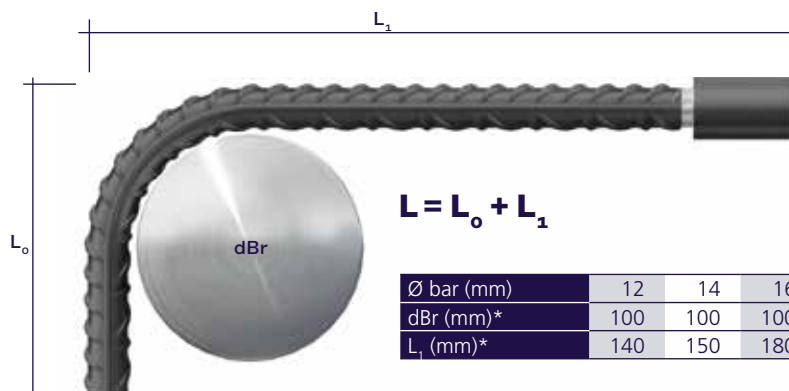

* Important information in relation to the CAC bars: the CAC couplers are, as standard, bent over a mandrel with a diameter as stated above. This results in a min. length L_1 . The diameter of the mandrel corresponds to 10 x the diameter of the bar. If the customer orders dimension L_1 smaller than the above, it will no longer correspond to 10 x the diameter. Any change in properties will be fully the responsibility of the customer.

CAM type

The straight CAM bar has a coupler on both ends.



CAF type

The straight CAF bar has a coupler on one end and a thread on the other.



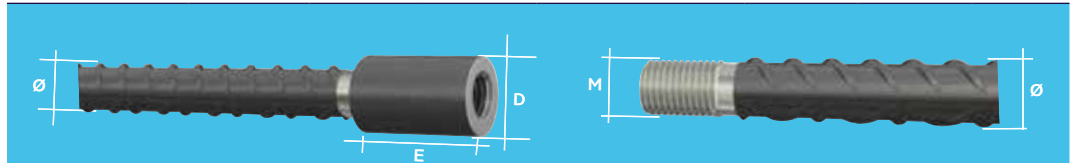

Ø bar (mm)	12	14	16	20	25	28	32	40
D (mm)	22	22	32	32	40	45	50	60
E (mm)	43	47	47	55	64	69	80	110
Thread	M13 x 1,75	M15 x 2	M17 x 2	M21 x 2,5	M26 x 3	M29 x 3	M33 x 3,5	M41 x 4
Weight of coupler (kg)	0,09	0,09	0,22	0,22	0,39	0,53	0,73	1,46
Tightening torque (Nm) ①	60	100	100	200	250	280	280	340
Modified wrench length (cm) ②	20	30	30	60	80	80	80	100

① The tightening torque is only applicable on the second phase bar.

② Small tightening torques are reached with 35 kg force using a modified wrench. More safety is possible using a torque wrench.

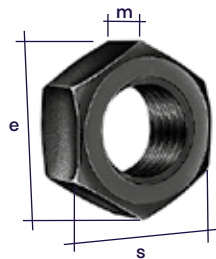

Coupler Box screw nut

Metric thread	s (mm)	e (mm)	m (mm)
M13	19	22	11
M15	22	25	12
M17	24	28	13
M21	30	34	16
M26	36	41	19
M29	41	47	22
M33	50	57	25
M41	59	68	32

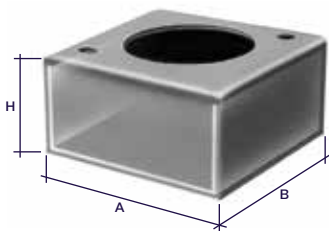

Monobox

Ø bar (mm)	12	14	16	20	25	28	32	40
A x B (mm x mm)	70x70	70x70	70x70	70x70	70x70	70x 0	70x70	70x70
H (mm)	25	25	25	25	25	25	25	25
Weight (kg)	0,08	0,08	0,08	0,08	0,08	0,07	0,07	0,07
Weight of cover (kg)	0,02	0,02	0,02	0,02	0,02	0,02	0,02	0,02

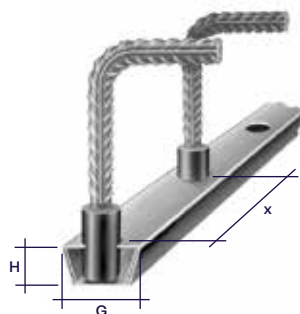

Multibox (length 1.20 m ; x = 100, 150, 200 mm)

Ø bar (mm)	12	14	16	20	25	28	32	40
G (mm)	60	60	60	60	60	60	60	90
H (mm)	28	28	28	28	28	28	28	28
Weight (kg/m)	0,93	0,93	0,93	0,93	0,93	0,93	0,93	1,05
Weight of slide (kg/m)	0,34	0,34	0,34	0,34	0,34	0,34	0,34	0,40

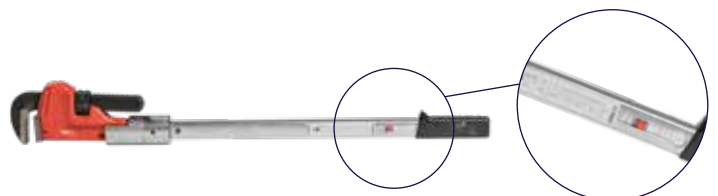



Couplerbox Applications

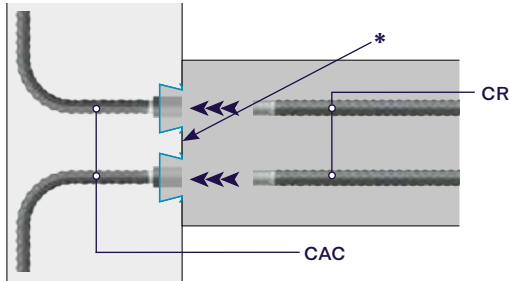

Wall to wall connection
Climbing or sliding formwork

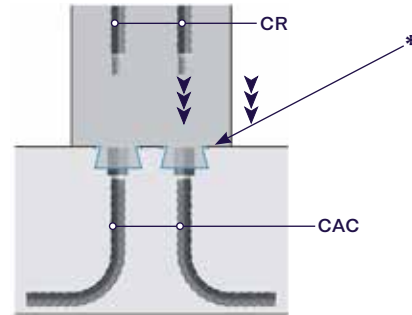

Floor to wall connection
Columns or walls on floor

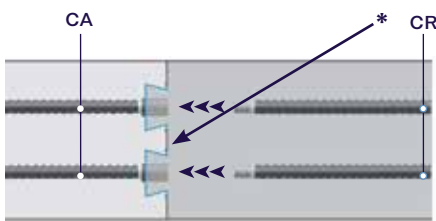

Floor to floor connection

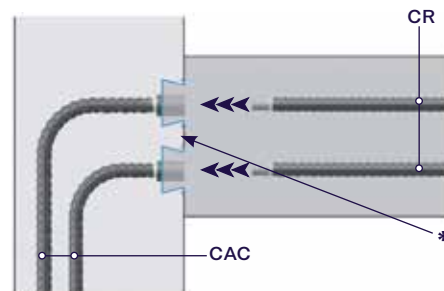

Wall to floor connection
Also for cast walls

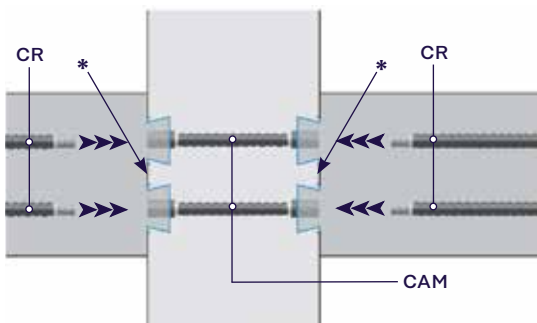

Floor to wall to floor connection
Anchoring with 2 couplers
Beam to column to beam connection

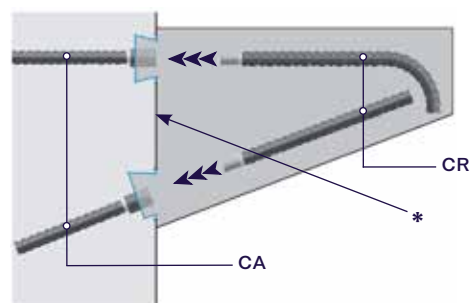

Wall to cantilever connection
Special covers give the Couplers an incline

* Ask us for advice about our waterproofing systems

Couplerbox Monobox en Multibox

The use of the Monobox or Multibox boxes simplifies positioning, reduces installation time and improves the quality of the connecting joint.



Tongue and groove connection of the Multibox.

The sides of the box are blocked by shrinkage.

The joint profile consists of a tongue and groove connection.

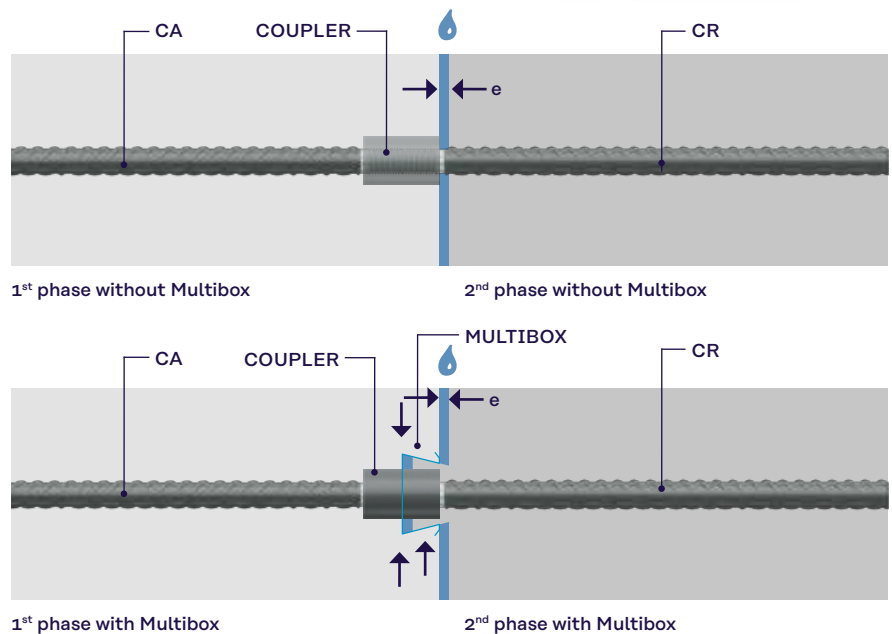

Advantages

- **Protecting the thread against corrosion**
 The concrete shrinkage 'e' causes the joint to open slightly so that condensation and seeping water could penetrate the thread on the coupler: the most stressed and weak zone on the coupling. Thanks to the Monobox or Multibox the thread is placed in a homogeneous phase of the concrete, protected from corrosion.
- **The coupler can easily be found**
 Once the coupler is covered by concrete it is difficult to find and to release. The use of the Monobox or Multibox solves this problem because the coupler is not fixed to the formwork: it can move freely over a distance of 25 mm in the box. The box is fixed to the formwork and can be easily found when the formwork is removed. Using the Multibox is especially efficient for cast walls and slurry walls.
- **Excellent fixing of the coupler**
 The coupler is supported by the Monobox or Multibox which guide the coupler while maintaining its position and orientation.
- **Increases the implementation tolerances**
 The presence of the Monobox or Multibox enables greater installation tolerances.



Couplerbox Toepassingen

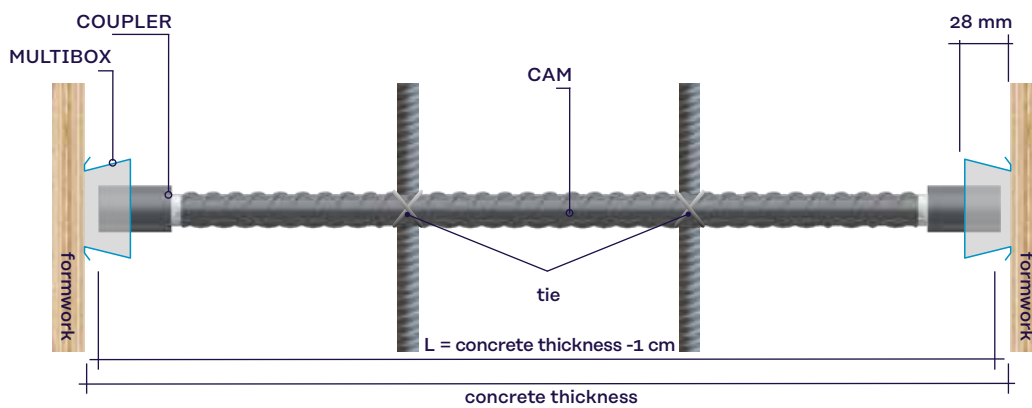
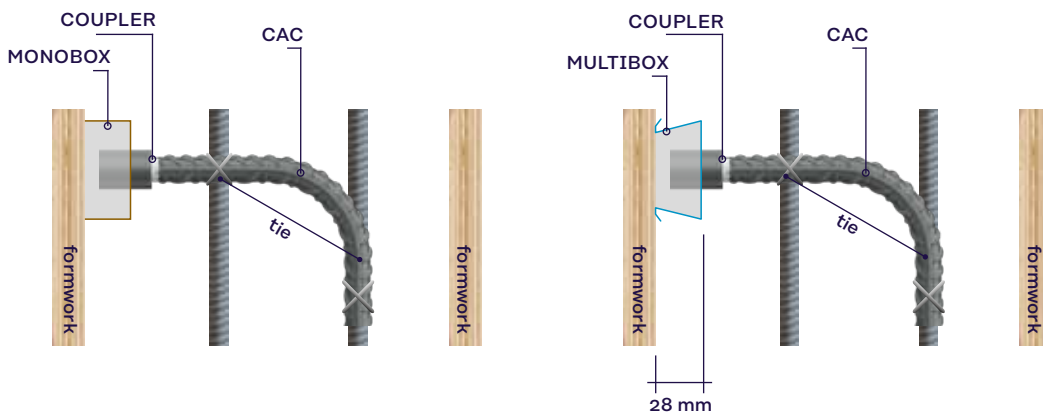

Instructions for use

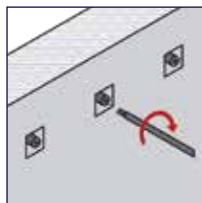
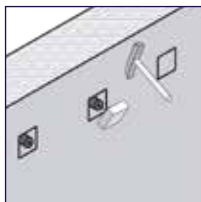
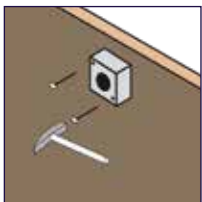

- Position and nail the Monobox or Multibox against the formwork
- Put the first phase CA, CAC or CAM type bar with a coupler and protective lid in the Box and tie the bar to the reinforcing
- Pour the concrete in the first phase
- When the formwork has been removed, remove the cover from the Monobox or Multibox and the protective lid from the coupler
- Screw the second phase type CR bar to the coupler
- Apply the correct tightening torque depending on the diameter of the bar

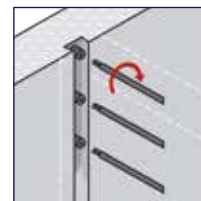
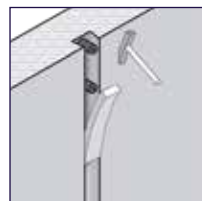
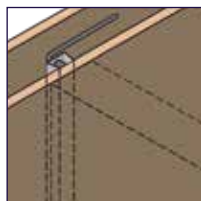

Couplerbox

Quality of Couplerbox jointing system

The Couplerbox jointing system complies with the criteria specified in various European standards. The system has approval (Zulassung) in Germany.

■ Resistance criteria

The fracture occurs at minimum 95% of the actual resistance of the weakest bar in the joint. The coupling may be treated as a continuous bar.

■ Lengthening criteria

Lengthening the joint (Agt) under maximum load is minimum 4%.

■ Sliding criteria

After 3 simultaneous load cycles at 60% of the yield strength and then back to the rest position, the permanent lengthening is ≤ 0.1 mm

■ Fatigue criteria

Dynamic loads cause fatigue problems (cracks, fractures). Thanks to its parallel rolled thread, the Coupler Box provides particularly good resistance in this kind of situation.

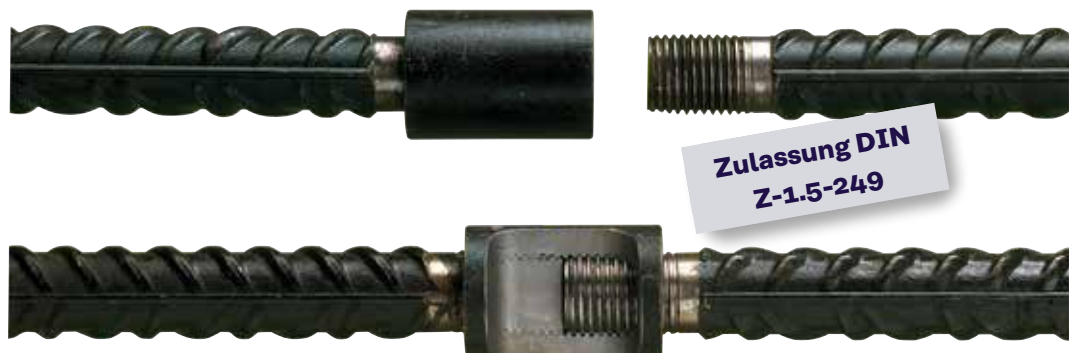

Contact Leviat worldwide

Australia

98 Kurrajong Avenue,
Mount Druitt, Sydney, NSW 2770
Tel: +61 - 2 8808 3100
Email: info.au@leviat.com

Austria

Leonard-Bernstein-Str. 10
Saturn Tower, 1220 Wien
Tel: +43 - 1 - 259 6770
Email: info.at@leviat.com

Belgium

Industrielaan 2
1740 Ternat
Tel: +32 - 2 - 582 29 45
Email: info.be@leviat.com

China

Room 601 Tower D,
Vantone Centre
No. A6 Chao Yang Men Wai Street
Chaoyang District
Beijing P.R. China 100020
Tel: +86 - 10 5907 3200
Email: info.cn@leviat.com

Czech Republic

Pekařská 695/10a
155 00 Praha 5
Tel: +420 - 311 - 690 060
Email: info.cz@leviat.com

Finland

Vädursgatan 5
412 50 Göteborg / Sweden
Tel: +358 (0)10 6338781
Email: info.fi@leviat.com

France

Carré Pleyel
5, Rue Pleyel
93200 Saint Denis
Tel: +33 (0)5 34 25 54 82
Email: info.fr@leviat.com

Germany

Liebigstrasse 14
40764 Langenfeld
Tel: +49 - 2173 - 970 - 0
Email: info.de@leviat.com

India

Unit S4, 902, A Wing,
Lodha iThink Techno Campus Building,
Panchpakhadi, Pokharan Road 2,
Thane, 400606
Tel: +91-022 695 33700
Email: info.in@leviat.com

Italy

Via F.lli Bronzetti 28
24124 Bergamo
Tel: +39 - 035 - 0760711
Email: info.it@leviat.com

Malaysia

28 Jalan Anggerik Mokara 31/59
Kota Kemuning,
40460 Shah Alam Selangor
Tel: +603 - 5122 4182
Email: info.my@leviat.com

Netherlands

Slachthuisweg 10
7556 AX Hengelo
Tel: +31 - 74 - 267 14 49
Email: info.nl@leviat.com

New Zealand

246D James Fletcher Drive, Otahuhu,
Auckland 2024
Tel: +64 - 9 276 2236
Email: info.nz@leviat.com

Philippines

27F Office A, Podium West Tower,
12 ADB Avenue, Ortigas Center
Mandaluyong City, 1550
Tel: +63 - 2 7957 6381
Email: info.ph@leviat.com

Poland

ul. Głogowska 151
60-206 Poznań
Tel: +48 - 61 - 622 14 14
Email: info.pl@leviat.com

Singapore

10 Benoi Sector,
Singapore 629845
Tel: +65 - 6266 6802
Email: info.sg@leviat.com

Spain

Poligono Industrial Santa Ana
c/ Ignacio Zuloaga, 20
28522 Rivas-Vaciamadrid
Tel: +34 - 91 632 18 40
Email: info.es@leviat.com

Sweden

Vädursgatan 5
412 50 Göteborg
Tel: +46 - 31 - 98 58 00
Email: info.se@leviat.com

Switzerland

Grenzstrasse 24
3250 Lyss
Tel: +41 (0)800 22 66 00
Email: info.ch@leviat.com

United Arab Emirates

RA08 TB02, PO Box 17225
JAFZA, Jebel Ali, Dubai
Tel: +971 (0)4 883 4346
Email: info.ae@leviat.com

United Kingdom

President Way,
President Park,
Sheffield S4 7UR
Tel: +44 - 114 275 5224
Email: info.uk@leviat.com

USA / Canada

6467 S Falkenburg Road
Riverview, FL 33578
Tel: (800) 423-9140
Email: info.us@leviat.us

For countries not listed
Email: info@leviat.com

Notes regarding this document

© Protected by copyright. The information in this publication is based on state-of-the-art technology at the time of publication. In every case, project working details should be entrusted to appropriately qualified and experienced persons. Leviat shall not accept liability for the accuracy of the information in this document or for any printing errors. We reserve the right to make technical and design changes at any time. With a policy of continuous product development, Leviat reserves the right to modify product design and specification at any time.

Leviat®

Imagine. Model. Make.

Leviat.com